

CHECKLIST: LAND USE PETITION

JOHNSON COUNTY DEPARTMENT OF PLANNING AND ZONING

All of the following items are required for a complete land use petition application.

- One completed **Checklist** (*this form*).
- One completed **Application**, signed by the owner of the subject property or an authorized agent, notarized.
- One copy of the property **Legal Description**, most likely a recorded deed, with Recorder's Stamp. The deed is available at the Johnson County Recorder's Office, 86 West Court Street, Franklin, Indiana.
- N/A One signed, notarized **Owner Consent Form** (required only if the petitioner does *not* own the subject property).
- Three copies of a **Site Plan** (for Variance and Special Exception petitions only; a site plan is *not* required for a rezoning). The site plan must clearly and accurately show the entire layout of the property including all structures, drives, parking areas and uses related to or proposed with the petition. The site plan must also include a north arrow, and must be drawn to scale. See the attached Sample Site Plan.
- One completed **Findings of Fact** form (for Variance and Special Exception petitions only; Findings of Fact are *not* required for a rezoning). See the attached guidance sheet.
- One **Plan of Operation** (for Variance of Use and Special Exception petitions only). The Plan of Operation should include, at minimum, information about anticipated numbers of customers and employees, shipping and receiving, waste handling, hours of operation, materials use, storage and display, and other site activities and operations.
- One non-refundable application **filing fee**. Checks are payable to "Johnson County". One signed On-site notice refundable deposit form.
- One **refundable deposit** for the On-Site Public Notice sign. An On-Site Notice sign must be placed in a conspicuous location along the subject property's street frontage(s).
- Contact person** information. The Contact Person will be notified when Legal Notice is prepared, will be contacted if additional information is necessary, will receive the written staff report prior to the hearing, and will represent the petition at the hearing.

Contact Person: _____

Address: _____

City, State, ZIP: _____

Phone number: _____ FAX: _____

Email address: _____

Preferred method of contact: EMAIL PHONE

LAND USE PETITION APPLICATION

JOHNSON COUNTY DEPARTMENT OF PLANNING AND ZONING

OFFICE USE ONLY	
Reviewed By: _____	Date: _____
Case Number: _____	Fee: _____
Receipt #: _____	Check #: _____
Sec: _____ Twp: _____	Range: _____
Zoning: _____	
Date of Hearing: _____	

Subject Property (E911 address): 3949 WOODMORE DR, GREENWOOD, IN 46142

Nearest Parcel Number: 41-03-26-033-049.000-038 Acreage: 0.38

Existing Use of Property: Public ROW - property owner is Johnson County

Existing Buildings/Improvements on Property: N/A

Petitioner Name: Emily Smith - TeleCAD on behalf of Verizon Wireless Phone Number: 423-802-7707

Email Address: matt.bates@telecadeng.com

Petitioner's Home Address: 1961 Northpoint Blvd, Suite 130

Nearest Property Owner Name (if different from petitioner): Smith, William

Nearest Property Owner Address (if different from petitioner): 3953 Woodmore Dr

This is nearest property but our proposal is located within the Public ROW.

Land Use Request (check all that apply):

- Variance of Use
- Variance of Development Standards
- Other (describe) _____
- Rezoning
- Special Exception

Describe Land Use Request (attach additional pages if necessary):

Installing new VZW owned black metal pole with light, with two antennas,
pole mounted cabinet and meter in ROW of Woodmore Dr.

The above information and attached exhibits, to my knowledge and belief, are true and correct.

State of Tennessee

County of Hamilton

Subscribed and sworn to before me this 16th day of February, 2022

My commission expires: 8/21/22

County of Residence: Hamilton

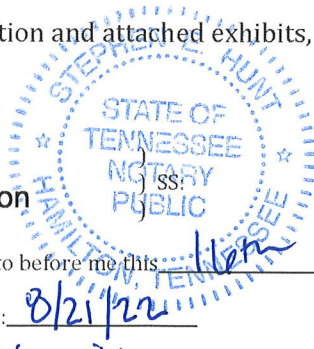

[Signature]
Signature of Petitioner
Emily N Smith - Telecad Wireless - on behalf of Verizon Wireless

STEPHEN E HUNT
Notary Public
[Signature]

PROJECT SUMMARY

SITE NAME: GN INDY 1324
 SITE ADDRESS: 3949 WOODMORE DR GREENWOOD, IN 46142 (E-911 VERIFIED)
 COUNTY: JOHNSON
 JURISDICTION: GREENWOOD
 SITE COORDINATES: 1A
 LATITUDE: 39° 37' 24.708" N (NAD 83)
 LONGITUDE: 86° 10' 31.224" W (NAD 83)
 ELEVATION: ±710'-3" (NAVD 88)
 PROPERTY DEFINITION: R.O.W.
 FUZE PROJECT ID: 16042453
 PSLC CODE: 604639
 EXISTING POLE HEIGHT: N/A
 PROPOSED POLE HEIGHT: 43'-0"
 PROPOSED POLE CLASS: N/A
 HIGHEST APPURTENANCE: 43'-0"
 STRUCTURE OWNER: VERIZON
 STRUCTURE TYPE: NEW METAL (BLACK RAL9004) MODEL: 178 LIGHT
 ENVIRONMENTAL REQ. : N/A

PROJECT DESCRIPTION

THESE DRAWINGS DEPICT A PORTION OF A PROPOSED SMALL CELL NETWORK BUILD INVOLVING INSTALLATION OF A NEW METAL (BLACK RAL9004) MODEL: 178 VERIZON OWNED LIGHT POLE, SETTING AN ANTENNA (OR ANTENNAS) ATOP THE POLE AND INSTALLING POLE MOUNTED EQUIPMENT ON THE POLE.

STRUCTURAL REVIEW

STRUCTURAL ANALYSIS PERFORMED BY OTHERS.



SITE NAME: GN INDY 1324

3949 WOODMORE DR
 GREENWOOD, IN 46142

SHEET INDEX

NO.	DESCRIPTION
T1	TITLE SHEET
GN1	GENERAL NOTES
C1	SITE LAYOUTS
C1A	SITE LAYOUT - AERIAL IMAGERY
C2	POLE ELEVATION
C3	ANTENNA LAYOUT
C4	SITE DETAILS
C5	SITE DETAILS
C6	EQUIPMENT DETAILS
E1	UTILITY SITE PLAN
E2	ELECTRICAL DETAILS
E3	SINGLE LINE DIAGRAM
S1	FOUNDATION DESIGN
S2	FOUNDATION DESIGN
S3	FOUNDATION DESIGN
S4	FOUNDATION DESIGN

PREPARED FOR:



PREPARED BY:

TeleCAD
 Wireless
 1961 NORTHPOINT BLVD, SUITE 130
 HIXSON, TN 37343
 PH: 423-843-9500
 FAX: 423-843-9509

DRAWING NOTICE:
 THE INFORMATION CONTAINED IN THIS SET OF DOCUMENTS IS PROPRIETARY BY NATURE. ANY USE OR DISCLOSURE OTHER THAN THAT WHICH RELATES TO THE CLIENT IS STRICTLY PROHIBITED.

DRAWN BY:	TMR
CHECKED BY:	CTD

REVISIONS

NO.	DATE	BY	DESCRIPTION
0	10/21/21	AJD	CONSTRUCTION ISSUE
D	10/21/21	KR	PRELIMINARY REVIEW
C	07/18/21	KR	PRELIMINARY REVIEW
B	03/23/21	MJB	PRELIMINARY REVIEW
A	03/12/20	TMR	PRELIMINARY REVIEW

ENGINEER'S STAMP:



NOT VALID WITHOUT P.E. STAMP & SIGNATURE

SCOPE OF WORK

- INSTALLING NEW METAL (BLACK RAL9004) MODEL: 178 LIGHT POLE
- INSTALLING EQUIPMENT
 - POLE MOUNTED FIBER CABINET
 - (2) ERICSSON ANTENNAS
 - (1) FIBER & (1) POWER CABLE PER ANTENNA
 - POWER METER & DISCONNECT
- RUN CONDUITS FOR POWER AND FIBER

STATE COUNTY MAP



VICINITY MAP

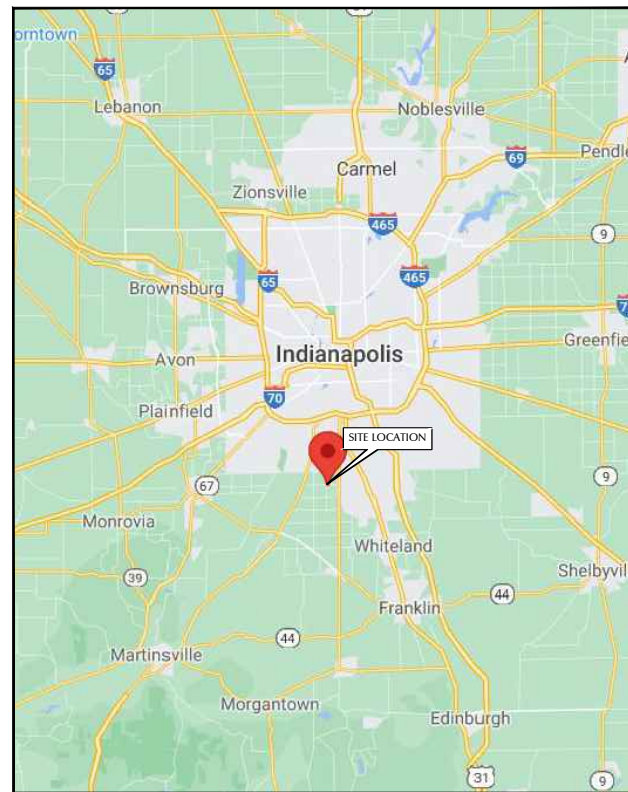

NOT TO SCALE

LOCATION MAP

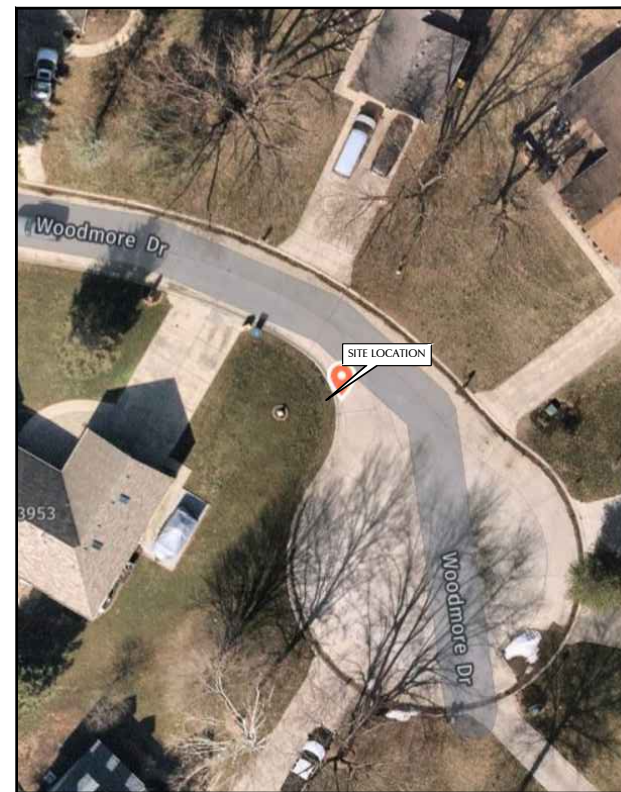

NOT TO SCALE

SHEET SCALE FACTOR:

PLOT SIZE:
 11" x 17": TO SCALE



1 (800) 382-5544
 www.indiana811.com
 CONTRACTOR TO CALL INDIANA
 ONE-CALL SYSTEMS AT LEAST (2) WORKING
 DAYS PRIOR TO DIGGING.

SITE NAME:

GN INDY 1324

ADDRESS:

3949 WOODMORE DR
 GREENWOOD, IN 46142

COUNTY:

JOHNSON

LATITUDE:

39° 37' 24.708" N

LONGITUDE:

86° 10' 31.224" W

DESIGN TYPE:

RAWLAND

SHEET TITLE:

TITLE SHEET

DRAWING NO.

T1

REVISION:

0

GENERAL NOTES

1. THESE NOTES SHALL BE CONSIDERED A PART OF THE WRITTEN SPECIFICATIONS.
2. THE WORK SHALL INCLUDE FURNISHING MATERIALS, EQUIPMENT, APPURTENANCES AND LABOR NECESSARY TO COMPLETE ALL INSTALLATIONS AS INDICATED IN THE CONTRACT DOCUMENTS.
3. PRIOR TO THE SUBMISSION OF BIDS, THE CONTRACTOR(S) SHALL VISIT THE JOB SITE(S) AND BE RESPONSIBLE FOR ALL CONTRACT DOCUMENTS, FIELD CONDITIONS AND DIMENSIONS AND CONFIRMING THAT THE WORK MAY BE ACCOMPLISHED PER THE CONTRACT DOCUMENTS. ANY DISCREPANCIES ARE TO BE BROUGHT TO THE ATTENTION OF THE IMPLEMENTATION ENGINEER AND ARCHITECT/ENGINEER.
4. THE CONTRACTOR SHALL RECEIVE WRITTEN AUTHORIZATION TO PROCEED ON ANY WORK NOT CLEARLY DEFINED OR IDENTIFIED IN THE CONSTRUCTION DOCUMENTS BEFORE STARTING ANY WORK.
5. ALL WORK PERFORMED AND MATERIALS INSTALLED SHALL BE IN STRICT ACCORDANCE WITH ALL APPLICABLE CODES, REGULATIONS AND ORDINANCES INCLUDING APPLICABLE MUNICIPAL AND UTILITY COMPANY SPECIFICATIONS.
6. THE CONTRACTOR SHALL INSTALL ALL EQUIPMENT AND MATERIALS IN ACCORDANCE WITH THE MANUFACTURER RECOMMENDATIONS. IF THESE RECOMMENDATIONS ARE IN CONFLICT WITH THE CONTRACT DOCUMENTS AND/OR APPLICABLE CODES OR REGULATIONS, REVIEW THE CONFLICT FOR DIRECTION WITH THE IMPLEMENTATION ENGINEER AND ARCHITECT/ENGINEER PRIOR TO PROCEEDING.
7. THE CONTRACTOR SHALL BE SOLELY RESPONSIBLE FOR ALL CONSTRUCTION MEANS, METHODS, TECHNIQUES, SEQUENCES, PROCEDURES AND FOR COORDINATION OF ALL PORTIONS OF THE WORK UNDER THE CONTRACT INCLUDING CONTACT AND COORDINATION WITH THE IMPLEMENTATION TEAM AND WITH THE AUTHORIZED REPRESENTATIVE OF ANY OUTSIDE POLE OR PROPERTY OWNER. (BASE COMMANDER OR AUTHORIZED AGENT)
8. THE CONTRACTOR SHALL MAKE NECESSARY PROVISIONS TO PROTECT EXISTING IMPROVEMENTS, PAVING, CURBS, VEGETATION, GALVANIZED SURFACE OR OTHER EXISTING ELEMENTS AND UPON COMPLETION OF THE WORK, REPAIR ANY DAMAGE THAT OCCURRED DURING CONSTRUCTION TO THE SATISFACTION OF EXTENT.
9. KEEP THE GENERAL AREA CLEAN, HAZARD FREE AND DISPOSE OF ALL DIRT, DEBRIS, RUBBISH AND REMOVE EQUIPMENT NOT SPECIFIED AS REMAINING ON THE PROPERTY. LEAVE PREMISES IN CLEAN CONDITION DAILY.
10. PLANS ARE INTENDED TO BE DIAGRAMMATIC ONLY AND SHOULD NOT BE SCALED UNLESS OTHERWISE NOTED. RELY ONLY ON ANNOTATED DIMENSIONS AND REQUEST INFORMATION IF ADDITIONAL DIMENSIONS ARE REQUIRED.
11. THE EXISTENCE AND LOCATION OF UTILITIES AND OTHER AGENCY'S FACILITIES ARE OBTAINED BY A SEARCH OF AVAILABLE RECORDS. OTHER FACILITIES MAY EXIST BEYOND WHAT IS NOTED. CONTRACTOR SHALL VERIFY LOCATIONS PRIOR TO START OF CONSTRUCTION AND USE EXTREME CARE AND PROTECTIVE MEASURES TO PREVENT DAMAGE TO THESE FACILITIES. CONTRACTOR IS RESPONSIBLE FOR THE PROTECTION OF UTILITIES OR OTHER AGENCY'S FACILITIES WITHIN THE LIMITS OF THE WORK, WHETHER THEY ARE IDENTIFIED IN THE CONTRACT DOCUMENTS OR NOT.
12. ALL MOUNTING HARDWARE SUCH AS BOLTS, NUTS, LAG SCREWS, CLEVIS, CONDUIT STRAPS, STAPLES, (ANYTHING EXPOSED AND CONNECTING EQUIPMENT TO THE POLE SHALL BE HOT DIPPED GALVANIZED, UNLESS OTHERWISE STATED)

DEFINITIONS

1. "TYPICAL" OR "TYP." MEANS THAT THIS ITEM IS VIRTUALLY IDENTICAL ACROSS SIMILAR CONDITIONS. "TYP." SHALL BE UNDERSTOOD TO MEAN "TYPICAL WHERE OCCURS" AND SHALL NOT BE CONSIDERED AS WITHOUT EXCEPTION OR CONSIDERATION OF SPECIFIC CONDITIONS.
2. "SIMILAR" MEANS COMPARABLE TO CHARACTERISTICS FOR CONDITION NOTED. VERIFY DIMENSIONS AND ORIENTATION ON PLAN.
3. "AS REQUIRED" MEANS AS REQUIRED BY REGULATORY REQUIREMENTS BY REFERENCED STANDARDS, BY EXISTING CONDITIONS, BY GENERALLY ACCEPTED CONSTRUCTION PRACTICE OR BY THE CONTRACT DOCUMENTS.
4. "ALIGN" MEANS ACCURATELY LOCATE FINISH FACES OF MATERIALS IN THE SAME PLANE.
5. THE TERM "VERIFY" OR "V.I.F." SHALL BE UNDERSTOOD TO MEAN VERIFY IN FIELD WITH ARCHITECT AND REQUIRES THAT THE CONTRACTOR CONFIRM INTENTION REGARDING NOTED CONDITION AND PROCEED ONLY AFTER RECEIVING DIRECTION.
6. WHERE THE WORDS "OR EQUAL" OR WORDS OF SIMILAR INTENT FOLLOW A MATERIAL SPECIFICATION, THEY SHALL BE UNDERSTOOD TO REQUIRE SIGNED APPROVAL OF ANY DEVIATION TO SAID SPECIFICATION PRIOR TO CONTRACTOR'S ORDERING OR INSTALLATION OF SUCH PROPOSED EQUAL PRODUCT.
7. FURNISH: SUPPLY ONLY, OTHERS TO INSTALL. INSTALL: ITEMS FURNISHED BY OTHERS. PROVIDE: FURNISH AND INSTALL.

PROJECT SPECIFIC NOTES

1. THIS SET IS PROVIDED TO ILLUSTRATE THE EXPECTED SCOPE OF DRAWINGS, QUALITY OF DRAWINGS AND EXTENT GRAPHIC STANDARDS. NOTES ARE FOR A&E CONTRACTOR REFERENCE TO HELP CLARIFY THE SCOPE. ADDITIONAL DRAWINGS MAY BE REQUIRED TO MEET THE REQUIREMENTS OF A GIVEN BASE. ALL EXAMPLES SHOWN ARE FOR REFERENCE ONLY AND ANY NOTES, DETAILS, CALCULATIONS OR OTHER WORK NEEDS TO BE COMPLETED OR CONFIRMED BY THE CONTRACTOR GENERATING THE DRAWINGS IN CONSTRUCTION DOCUMENTS.
2. IT IS THE RESPONSIBILITY OF THE CONTRACTOR TO DETERMINE AND ADDITIONAL DRAWINGS OR REQUIREMENTS FOR EACH BASE, INCLUDING ANY REQUIRED DESIGNATIONS IN THE TITLE BLOCK TO INDICATE THE SUBMITTAL OR PERMIT NUMBER.
3. THIS SET IS TO BE PRINTED AT 11" x 17". IT IS THE RESPONSIBILITY OF THE CONTRACTOR TO CONFIRM THIS SIZE IS ACCEPTABLE BY THE BASE AND TO PROVIDE A LARGER STANDARD SIZE IF REQUIRED.
4. IT IS THE RESPONSIBILITY OF THE GENERAL CONTRACTOR TO CONFIRM ALL WORK SHOWN IS IN COMPLIANCE WITH BASE AND FEDERAL CODES. DRAWINGS SHOWN WITHIN THIS SET ARE SAMPLES AND MAY NOT REFLECT ALL OF THE REQUIRED ELEMENTS, CLEARANCES OR OTHER ITEMS OF ASSEMBLIES NEEDED TO BE CODE COMPLIANT IN THE PARTICULAR MUNICIPALITY THE NODE IS LOCATED WITHIN.

GROUND CONSTRUCTION NOTES:

1. 120/240V POWER REQUIRED FOR 3-WIRE SERVICE.
2. GC TO REMOVE / CLEAN ALL DEBRIS, NAILS, STAPLES, OR NON-USED VERTICALS OFF THE EXISTING POLE.
3. ALL CONSTRUCTION SHALL BE IN ACCORDANCE WITH FEDERAL STANDARDS AND REGULATIONS AS WELL AS NEC.
4. CALL INDIANA ONE CALL AT LEAST 2 WORKING DAYS PRIOR TO EXCAVATING AT (800) 382-5544.
5. ALL LANDSCAPING TO BE RESTORED TO ORIGINAL CONDITION OR BETTER.
6. ALL EQUIPMENT TO BE BONDED.
7. METERING CABINET (IF INSTALLED) REQUIRES 3' CLEARANCE AT DOOR OPENING.

STANDARD GROUNDING NOTES:

1. GROUND TESTED AT 25 OHMS OR LESS.
2. 5/8" x 8' RODS, CAD WELD OR UL LISTED DIRECT BURY CLAMP BELOW GRADE.
3. #6 GROUND AND BOND WIRE.
4. MOLDING, STAPLED EVERY 1' AND AT EACH END.
5. GROUND RODS 18" FROM POLE.

STANDARD CONDUIT NOTES:

1. FOR UNDERGROUND CONDUIT AND ABOVE GRADE RISERS USE SCHEDULE 40.
2. IF DIRECTIONAL BORING PLACE 1-1/4" SDR-11 GRAY CONDUIT FOR UNDERGROUND POWER APPLICATIONS.
3. IF TRENCHING PLACE 1-1/4" PVC SCH 40 CONDUIT FOR UNDERGROUND POWER APPLICATIONS.
4. RISERS TO BE ATTACHED TO POLE WITH STANDARD STRAPS AND LAG SCREWS.
5. RISER STRAPS TO BE INSTALLED EVERY 5'.
6. CONDUIT UNDER 1" MAY BE ATTACHED WITH GROUND WIRE MOLDING STAPLES.
7. ALL CONDUIT WILL BE PROOFED WITH A MANDREL AND EQUIPPED WITH PULL ROPE OR MULE TAPE.

STANDARD TRENCHING NOTES:

1. MAINTAIN 46" MINIMUM COVER FOR ELECTRICAL CONDUIT.
2. MAINTAIN 46" MINIMUM COVER FOR COMMUNICATION CONDUIT.
3. IN STREET SLURRY TO GRADE AND MILL DOWN 1-1/2" FOR AC CAP.
4. IN DIRT SLURRY 18" FROM GRADE AND FILL WITH 95% COMPACTION NATIVE SOIL FOR BALANCE.
5. PLACE WARNING TAPE IN TRENCH 12" ABOVE ALL CONDUITS AND #18 WARNING TAPE ABOVE GROUND EQUIPMENT.

UTILITY POLE CONSTRUCTION NOTES:

1. NO BOLT THREADS TO PROTRUDE MORE THAN 1/2".
2. FILL ALL HOLES LEFT IN POLE FROM REARRANGEMENT OF CLIMBERS.
3. ALL CLIMB STEPS NEXT TO CONDUIT SHALL HAVE EXTENDED STEPS.
4. CABLE NOT TO IMPEDE 15" CLEAR SPACE OFF POLE FACE.
5. 90° SHORT SWEEP UNDER ANTENNA ARM. ALL CABLES MUST ONLY TRANSITION ON THE INSIDE OR BOTTOM OF ARMS (NO CABLE ON TOP OF ARMS).
6. USE CABLE CLAMPS TO SECURE CABLE TO ARMS; PLACE 2" CARRIER ID TAGS ON BOTH SIDE OF ARMS.
7. USE 90° CONNECTOR AT CABLE CONNECTION TO ANTENNAS.
8. USE 1/2" CABLE ON ANTENNAS UNLESS OTHERWISE SPECIFIED.
9. FILL VOID AROUND CABLES AT CONDUIT OPENING WITH FOAM SEALANT TO PREVENT WATER INTRUSION.

VERIZON WIRELESS CONSTRUCTION NOTES:

1. CONTRACTOR IS TO FOLLOW THE MOST CURRENT VZW STANDARDS DOCUMENTS PROVIDED TO COMPLETE THIS INSTALLATION.
2. CONTRACTOR SHALL COMPLETE VZW PROVIDED "SMALL CELL SWEEP REPORT" WITH ALL INFORMATION FILLED IN ACCURATELY AND COMPLETELY.
3. CONTRACTOR TO REFER TO THE MOST CURRENT VZW STANDARDS FOR APPROVED "PIM" TEST EQUIPMENT AND GUIDELINES.
4. CONTRACTOR IS TO USE BATTERY POWERED "PIM" EQUIPMENT TO VALIDATE THE FINAL LOCATION OF THE JUMPER AND ANTENNA ARE FREE OF INTERNAL AND EXTERNAL "PIM" SOURCES.
5. CONTRACTOR SHALL PROVIDE AT LEAST ONE TECHNICAL LEAD THAT IS CERTIFIED AND PROFICIENT IN EXECUTING, INTERPRETING AND RECORDING "PIM" MEASUREMENTS.

PREPARED FOR:

verizon

PREPARED BY:

TeleCAD
Wireless

1961 NORTHPOINT BLVD, SUITE 130
HIXSON, TN 37343
PH: 423-843-9500
FAX: 423-843-9509

DRAWING NOTICE:

THE INFORMATION CONTAINED IN THIS SET OF DOCUMENTS IS PROPRIETARY BY NATURE. ANY USE OR DISCLOSURE OTHER THAN THAT WHICH RELATES TO THE CLIENT IS STRICTLY PROHIBITED.

DRAWN BY:

TMR

CHECKED BY:

CTD

REVISIONS

NO.	DATE	BY	DESCRIPTION
0	10/21/21	AJD	CONSTRUCTION ISSUE
D	10/21/21	KR	PRELIMINARY REVIEW
C	07/18/21	KR	PRELIMINARY REVIEW
B	03/23/21	MJB	PRELIMINARY REVIEW
A	03/12/20	TMR	PRELIMINARY REVIEW

ENGINEER'S STAMP:



NOT VALID WITHOUT P.E. STAMP & SIGNATURE

SITE NAME:

GN INDY 1324

ADDRESS:

3949 WOODMORE DR
GREENWOOD, IN 46142

COUNTY:

JOHNSON

LATITUDE:

39° 37' 24.708" N

LONGITUDE:

86° 10' 31.224" W

DESIGN TYPE:

RAWLAND

SHEET TITLE:

GENERAL NOTES

DRAWING NO.

GN1

REVISION:

0

NOTES:

1. THIS DRAWING IS BASED ON AERIAL IMAGERY AND FIELD OBSERVATIONS. CONTRACTOR SHALL FIELD VERIFY ALL EXISTING CONDITIONS PRIOR TO COMMENCEMENT OF CONSTRUCTION.
2. THE PROPOSED USE DOES NOT REQUIRE FULL OR PART TIME EMPLOYEES AT THE SITE.
3. FOR GENERAL SITE WORK NOTES, SEE SHEET GN1.
4. ALL NORTH ARROWS ON SITE PLANS ARE TRUE NORTH, UNLESS OTHERWISE SPECIFIED.
5. OPEN CUT CONSTRUCTION THROUGH EXISTING PAVEMENT, I.E. ROADWAYS, PARKING AREAS, SIDEWALKS WILL NOT BE ALLOWED. CONSTRUCTION UNDER EXISTING PAVEMENTS WILL BE REQUIRED TO BE INSTALLED WITH DIRECTIONAL BORING TECHNIQUE.

LEGEND

OVERHEAD UTILITIES	— DHU —	CATCH BASIN	⊞
UNDERGROUND POWER	— UGP — UGP —	STREET SIGN	—
OVERHEAD POWER	— DHP — DHP —	4 WAY STREET SIGN	+
UNDERGROUND TELCO	— UGT —	UTILITY POLE	⊙
OVERHEAD TELCO	— DHT —	LIGHT POLE	⊙
GAS LINE	— GAS — GAS —	WATER VALVE	⊗
FENCE	— x — x — x — x — x —	MANHOLE	⊙
WOOD FENCE	— o — o — o — o — o —	GAS VALVE	⊗
SEWER LINE	— SWR — SWR —	FIRE HYDRANT	⊙
WATER LINE	— WTR — WTR —	TELCO PEDESTAL	⊞
HYBRID CABLE	— HYB —	ELECTRICAL BOX	⊞
HIGH VOLTAGE POWER	— HVP —		
FIBER	— FBR — FBR —		
RIGHT-OF-WAY	— RDW — RDW —		
PROPERTY LINE	— PL — PL —		

UTILITY NOTE:

THE LOCATIONS OF EXISTING UNDERGROUND UTILITIES HAVE NOT BEEN VERIFIED. THE CONTRACTOR SHALL DETERMINE THE EXACT LOCATION OF ALL EXISTING UTILITIES BEFORE COMMENCING WORK. THE CONTRACTOR SHALL BE FULLY RESPONSIBLE FOR ANY AND ALL DAMAGES WHICH MIGHT OCCUR BY THE CONTRACTOR'S FAILURE TO EXACTLY LOCATE AND PRESERVE ANY AND ALL UNDERGROUND UTILITIES.

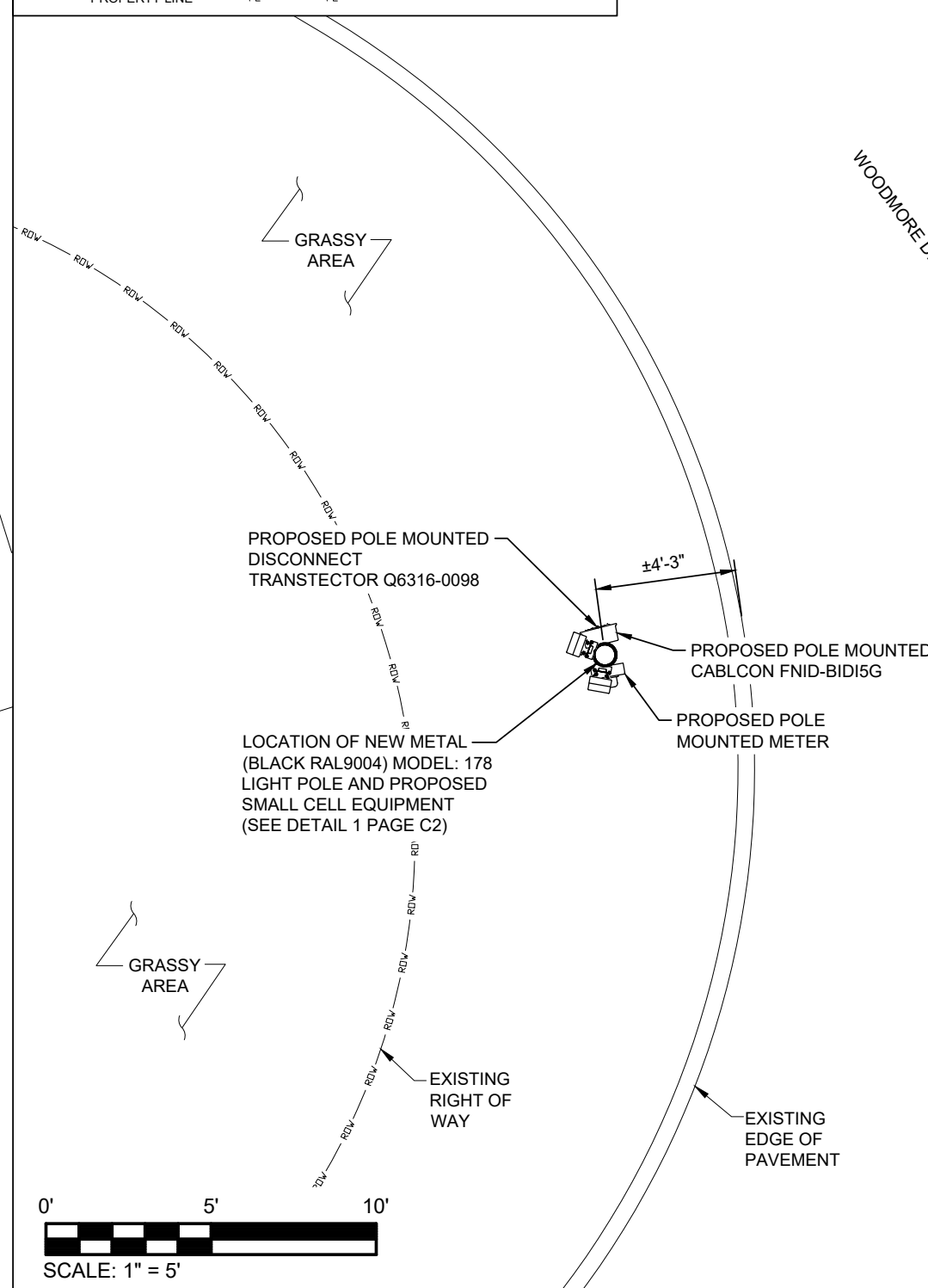
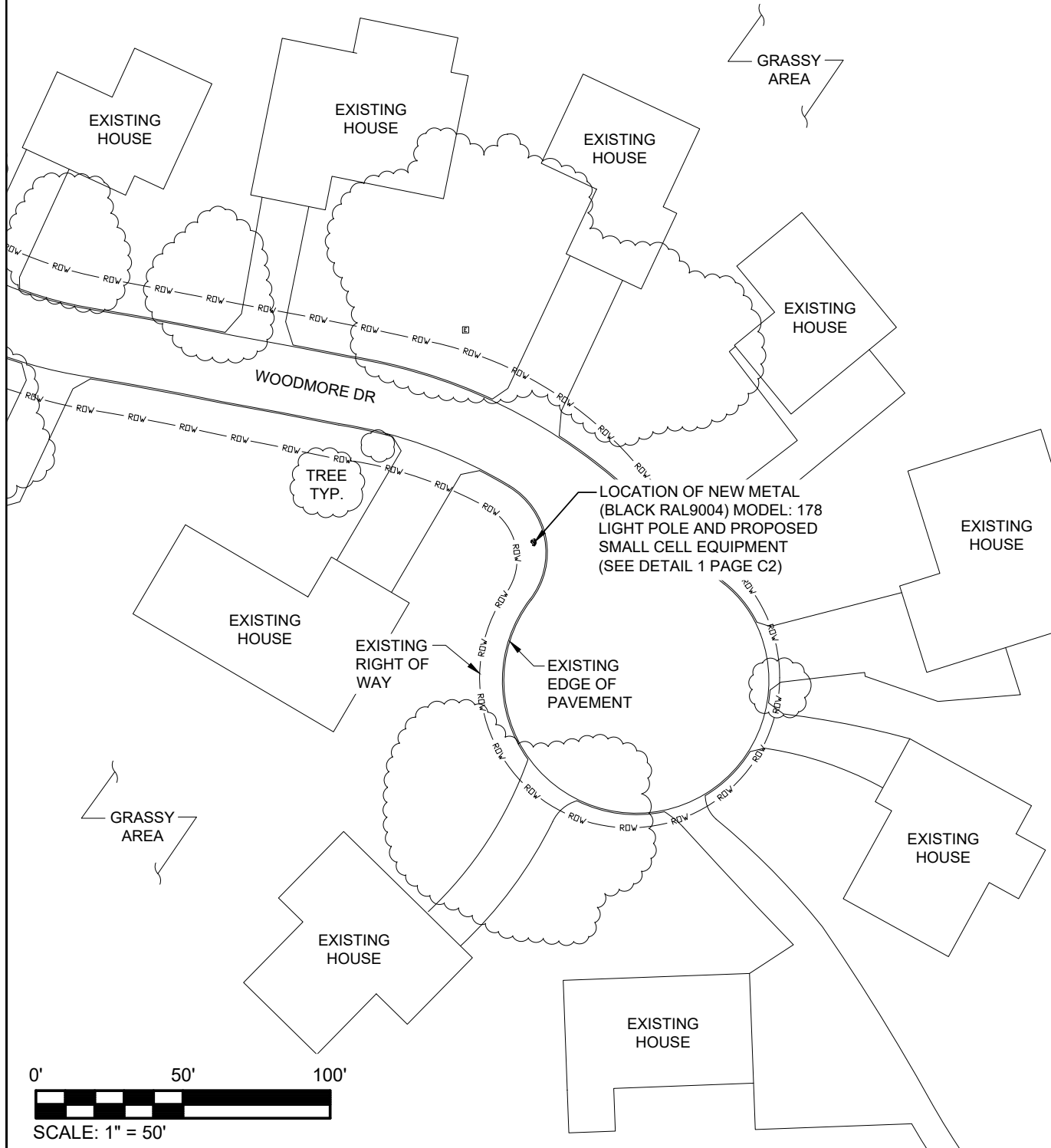

PREPARED FOR:



PREPARED BY:



1961 NORTHPOINT BLVD, SUITE 130
HIXSON, TN 37343
PH: 423-843-9500
FAX: 423-843-9509

DRAWING NOTICE:
THE INFORMATION CONTAINED IN THIS SET OF DOCUMENTS IS PROPRIETARY BY NATURE. ANY USE OR DISCLOSURE OTHER THAN THAT WHICH RELATES TO THE CLIENT IS STRICTLY PROHIBITED.

DRAWN BY: TMR
CHECKED BY: CTD

REVISIONS

NO.	DATE	BY	DESCRIPTION
0	10/21/21	AJD	CONSTRUCTION ISSUE
D	10/21/21	KR	PRELIMINARY REVIEW
C	07/18/21	KR	PRELIMINARY REVIEW
B	03/23/21	MJB	PRELIMINARY REVIEW
A	03/12/20	TMR	PRELIMINARY REVIEW

ENGINEER'S STAMP:



NOT VALID WITHOUT P.E. STAMP & SIGNATURE

SITE NAME: GN INDY 1324

ADDRESS: 3949 WOODMORE DR
GREENWOOD, IN 46142

COUNTY: JOHNSON

LATITUDE: 39° 37' 24.708" N

LONGITUDE: 86° 10' 31.224" W

DESIGN TYPE: RAWLAND

SHEET TITLE: SITE LAYOUTS

DRAWING NO. C1
REVISION: 0

1 OVERALL SITE LAYOUT

2 ENLARGED SITE LAYOUT



PREPARED FOR:



PREPARED BY:



1961 NORTHPOINT BLVD, SUITE 130
 HIXSON, TN 37343
 PH: 423-843-9500
 FAX: 423-843-9509

DRAWING NOTICE:
 THE INFORMATION CONTAINED IN THIS SET OF DOCUMENTS IS PROPRIETARY BY NATURE. ANY USE OR DISCLOSURE OTHER THAN THAT WHICH RELATES TO THE CLIENT IS STRICTLY PROHIBITED.

DRAWN BY:	TMR
CHECKED BY:	CTD

REVISIONS

NO.	DATE	BY	DESCRIPTION
0	10/21/21	AJD	CONSTRUCTION ISSUE
D	10/21/21	KR	PRELIMINARY REVIEW
C	07/18/21	KR	PRELIMINARY REVIEW
B	03/23/21	MJB	PRELIMINARY REVIEW
A	03/12/20	TMR	PRELIMINARY REVIEW

ENGINEER'S STAMP:

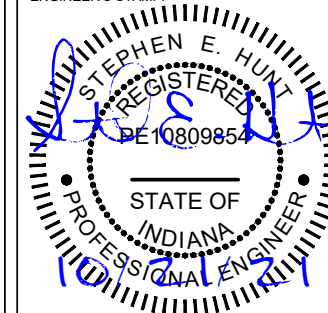

NOT VALID WITHOUT P.E. STAMP & SIGNATURE

SITE NAME:
GN INDY 1324

ADDRESS:
3949 WOODMORE DR
GREENWOOD, IN 46142

COUNTY:
JOHNSON

LATITUDE:
39° 37' 24.708" N

LONGITUDE:
86° 10' 31.224" W

DESIGN TYPE:
RAWLAND

SHEET TITLE:
SITE LAYOUT -
AERIAL IMAGERY

DRAWING NO. C1A	REVISION: 0
---------------------------	-----------------------

CONTRACTOR TO OBTAIN LATEST RFDS FROM VERIZON PRIOR TO CONSTRUCTION.

MAINTAIN A MIN. OF 3'-0" CLEARANCE BETWEEN DISCONNECT BOX AND ANY COMM LINES

40" MIN. CLEARANCE BELOW NEW TRIPLEX SERVICE

CONTRACTOR TO REINSTALL SIGNAGE AS REQUIRED.



PROPOSED ERICSSON 6701 ANTENNA

2'-0" TO SIGN

±7'-9"

±6'-0"

METAL POLE PART# CHART	
POLE MANUFACTURER	COMPTEK
POLE MODEL	178
POLE COLOR	BLACK RAL9004
LIGHT MODEL	STANDARD-6
LIGHT ARM MODEL	STANDARD-6

NEW METAL (BLACK RAL9004) MODEL: 178 LIGHT POLE

PROPOSED POLE MOUNTED CABLCON FNID-BIDI5G

PROPOSED POLE MOUNTED DISCONNECT TRANSECTOR Q6316-0098



8"X10" RF INFORMATION SIGN TO BE PLACED AS SHOWN

PROPOSED METER

5'-4"

8'-2"

11'-0"

FINISH GRADE

PROPOSED 4"Ø SCH 80 PVC CONDUIT TO POWER SOURCE

PROPOSED 2"Ø SCH 80 PVC CONDUIT TO FIBER SOURCE

30'-0" LIGHT MOUNT

±31'-10" LIGHT HEIGHT

39'-8" ANTENNA CENTERLINE

43'-0" TOP OF POLE

CONTRACTOR TO WRAP THE ANTENNAS AND PAINT THE EQUIPMENT TO MATCH THE POLE

PREPARED FOR:



PREPARED BY:

TeleCAD Wireless
 1961 NORTHPOINT BLVD, SUITE 130
 HIXSON, TN 37343
 PH: 423-843-9500
 FAX: 423-843-9509

DRAWING NOTICE:
 THE INFORMATION CONTAINED IN THIS SET OF DOCUMENTS IS PROPRIETARY BY NATURE. ANY USE OR DISCLOSURE OTHER THAN THAT WHICH RELATES TO THE CLIENT IS STRICTLY PROHIBITED.

DRAWN BY: TMR
 CHECKED BY: CTD

REVISIONS			
NO.	DATE	BY	DESCRIPTION
0	10/21/21	AJD	CONSTRUCTION ISSUE
D	10/21/21	KR	PRELIMINARY REVIEW
C	07/16/21	KR	PRELIMINARY REVIEW
B	03/23/21	MJB	PRELIMINARY REVIEW
A	03/12/20	TMR	PRELIMINARY REVIEW

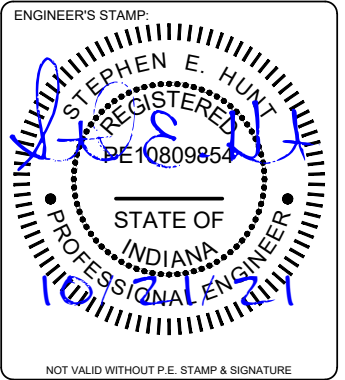

SITE NAME: GN INDY 1324
 ADDRESS: 3949 WOODMORE DR GREENWOOD, IN 46142
 COUNTY: JOHNSON
 LATITUDE: 39° 37' 24.708" N
 LONGITUDE: 86° 10' 31.224" W
 DESIGN TYPE: RAWLAND

SHEET TITLE: POLE ELEVATION

DRAWING NO. C2 REVISION: 0

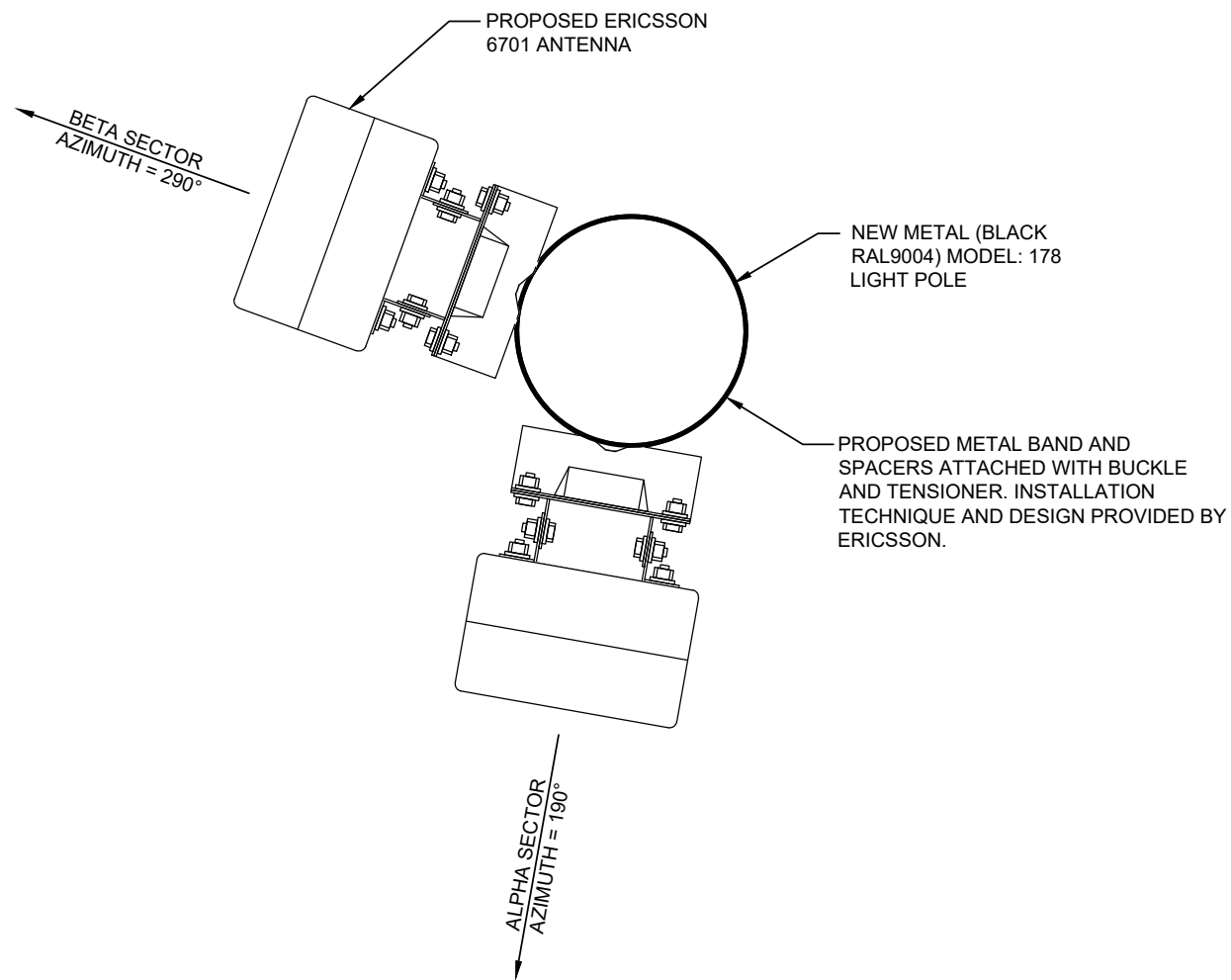

AZIMUTHS ARE SUBJECT TO CHANGE. CONTRACTOR TO VERIFY AZIMUTHS FROM FINAL RFDS FROM VERIZON. ANTENNA MOUNT TO BE SUPPLIED AND INSTALLED BY ERICSSON.

1 ANTENNA LAYOUT PLAN

N.T.S.

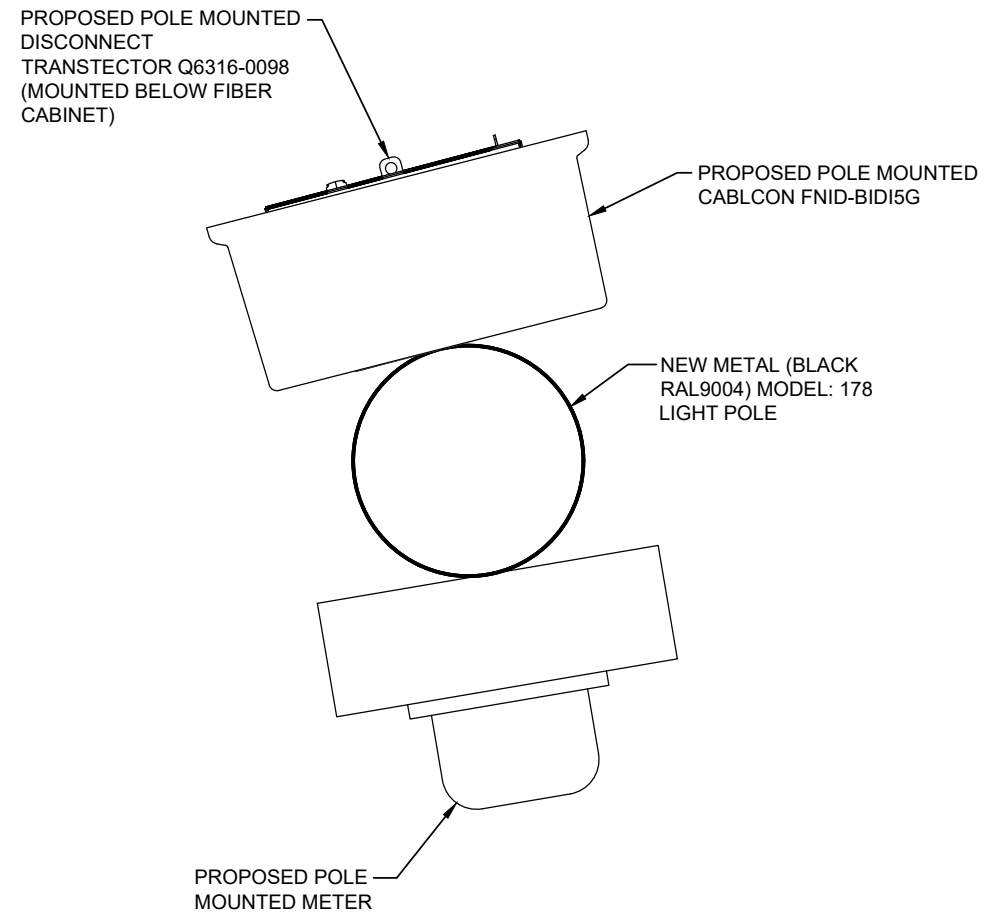

2 POLE MOUNTED EQUIPMENT LAYOUT PLAN

N.T.S.

PREPARED FOR:



PREPARED BY:



1961 NORTHPOINT BLVD, SUITE 130
HIXSON, TN 37343
PH: 423-843-9500
FAX: 423-843-9509

DRAWING NOTICE:
THE INFORMATION CONTAINED IN THIS SET OF DOCUMENTS IS PROPRIETARY BY NATURE. ANY USE OR DISCLOSURE OTHER THAN THAT WHICH RELATES TO THE CLIENT IS STRICTLY PROHIBITED.

DRAWN BY: TMR
CHECKED BY: CTD

REVISIONS

NO.	DATE	BY	DESCRIPTION
0	10/21/21	AJD	CONSTRUCTION ISSUE
D	10/21/21	KR	PRELIMINARY REVIEW
C	07/18/21	KR	PRELIMINARY REVIEW
B	03/23/21	MJB	PRELIMINARY REVIEW
A	03/12/20	TMR	PRELIMINARY REVIEW

ENGINEER'S STAMP:



NOT VALID WITHOUT P.E. STAMP & SIGNATURE

SITE NAME: GN INDY 1324
ADDRESS: 3949 WOODMORE DR
GREENWOOD, IN 46142
COUNTY: JOHNSON
LATITUDE: 39° 37' 24.708" N
LONGITUDE: 86° 10' 31.224" W
DESIGN TYPE: RAWLAND

SHEET TITLE: ANTENNA LAYOUT

DRAWING NO. C3
REVISION: 0

PREPARED FOR:



PREPARED BY:



1961 NORTHPOINT BLVD, SUITE 130
HIXSON, TN 37343
PH: 423-843-9500
FAX: 423-843-9509

DRAWING NOTICE:
THE INFORMATION CONTAINED IN THIS SET OF DOCUMENTS IS PROPRIETARY BY NATURE. ANY USE OR DISCLOSURE OTHER THAN THAT WHICH RELATES TO THE CLIENT IS STRICTLY PROHIBITED.

DRAWN BY: TMR
CHECKED BY: CTD

REVISIONS

NO.	DATE	BY	DESCRIPTION
0	10/21/21	AJD	CONSTRUCTION ISSUE
D	10/21/21	KR	PRELIMINARY REVIEW
C	07/16/21	KR	PRELIMINARY REVIEW
B	03/23/21	MJB	PRELIMINARY REVIEW
A	03/12/20	TMR	PRELIMINARY REVIEW

ENGINEER'S STAMP:

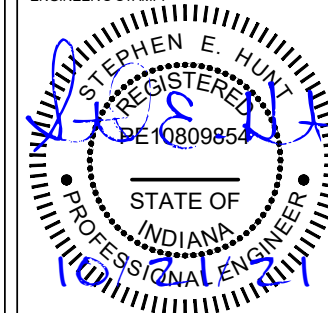

NOT VALID WITHOUT P.E. STAMP & SIGNATURE

SITE NAME: GN INDY 1324
ADDRESS: 3949 WOODMORE DR
GREENWOOD, IN 46142
COUNTY: JOHNSON
LATITUDE: 39° 37' 24.708" N
LONGITUDE: 86° 10' 31.224" W
DESIGN TYPE: RAWLAND

SHEET TITLE: SITE DETAILS

DRAWING NO. C4
REVISION: 0

POLE ATTACHED EQUIPMENT	
EQUIPMENT	VOLUME (CU-FT)
ERICSSON 6701 ANTENNA	0.46
ERICSSON 6701 ANTENNA	0.46
TOTAL IN CU-FT	0.92



PREPARED BY:
TeleCAD
 Wireless
 1961 NORTHPOINT BLVD, SUITE 130
 HIXSON, TN 37343
 PH: 423-843-9500
 FAX: 423-843-9509

DRAWING NOTICE:
 THE INFORMATION CONTAINED IN THIS SET OF DOCUMENTS IS PROPRIETARY BY NATURE. ANY USE OR DISCLOSURE OTHER THAN THAT WHICH RELATES TO THE CLIENT IS STRICTLY PROHIBITED.

DRAWN BY: TMR
 CHECKED BY: CTD

REVISIONS			
NO.	DATE	BY	DESCRIPTION
0	10/21/21	AJD	CONSTRUCTION ISSUE
D	10/21/21	KR	PRELIMINARY REVIEW
C	07/16/21	KR	PRELIMINARY REVIEW
B	03/23/21	MJB	PRELIMINARY REVIEW
A	03/12/20	TMR	PRELIMINARY REVIEW

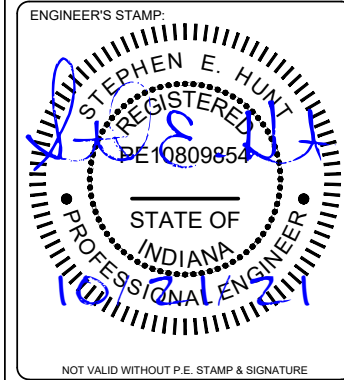

SITE NAME: GN INDY 1324
 ADDRESS: 3949 WOODMORE DR
 GREENWOOD, IN 46142
 COUNTY: JOHNSON
 LATITUDE: 39° 37' 24.708" N
 LONGITUDE: 86° 10' 31.224" W
 DESIGN TYPE: RAWLAND

SHEET TITLE: SITE DETAILS

DRAWING NO. C5
 REVISION: 0

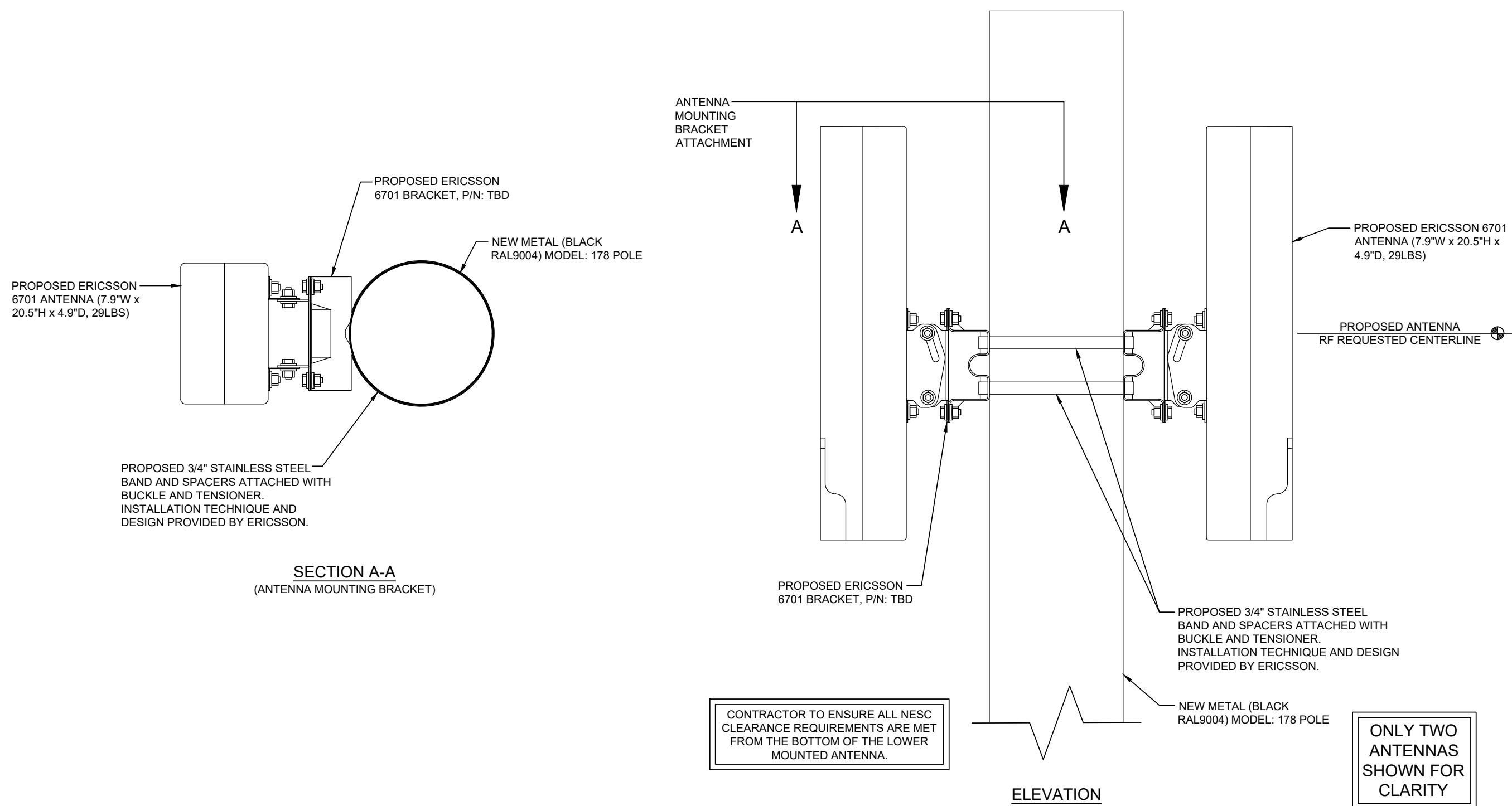

CONTRACTOR TO ENSURE ALL NESC CLEARANCE REQUIREMENTS ARE MET FROM THE BOTTOM OF THE LOWER MOUNTED ANTENNA.

ONLY TWO ANTENNAS SHOWN FOR CLARITY

Technical Data

Description	Value
Frequency	N261 (27.5–28.35 GHz)
Number of carriers	Config mode 2: Up to 8 Config mode 1: Up to 16
Operating bandwidth	Config mode 2: 800 MHz Config mode 1: 1600 MHz
Component carrier bandwidth	50MHz, 100 MHz
EIRP ⁽¹⁾	Config mode 2: 53 dBm per RF beam in boresight , 56 dBm per radio Config mode 1: 47 dBm per RF beam in boresight , 53 dBm per radio
EIS _{REFSENS_50M}	Config mode 2: -109 dBm Config mode 1: -106 dBm

(1) The MaxTxPower can be configured up to 10 dB lower than the stated EIRP without product performance being degraded. If the MaxTxPower is configured lower than the given power limit here, significant performance degradation will occur.

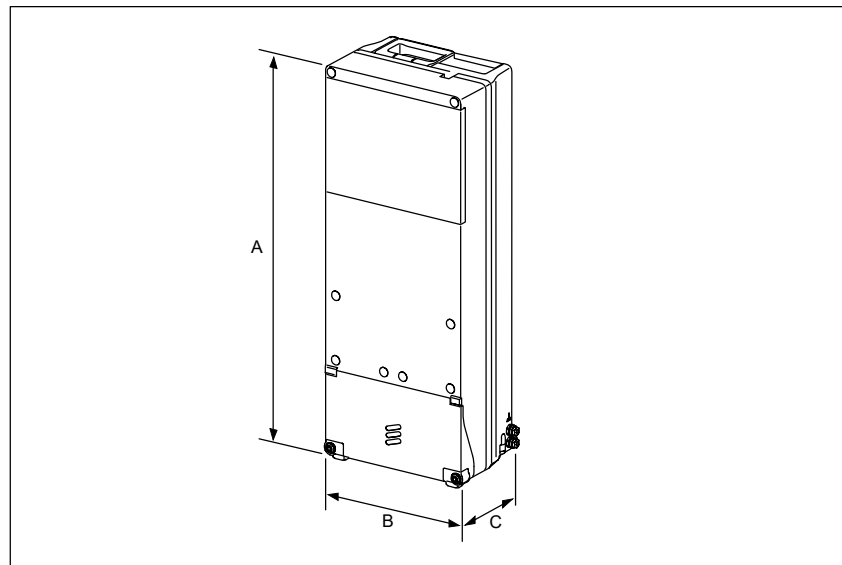

Dimensions, Weight, and Color

Dimensions	
Height (A)	511 mm
Width (B)	200 mm
Depth (C)	125 mm
Weight	14 kg
Color	Gray Reference number: NCS S 1002-B

ASSEMBLY BILL OF MATERIALS

ITEM	QTY	CABLCON PART NUMBER
1	1	Q6316-0026
2	1	Q6316-0001
3	2	Q6914-0340
4	2	Q6914-0365
5	1	Q6313-9934
6	4	Q6914-0309
7	10	Q9009-0229
8	29	THT-75-427-3
9	1	Q6313-9930
10	4	Q6313-9936
11	2	Q6914-0012
12	4	Q6914-0171
13	4	Q6914-0182
14	2	Q6914-0011
15	4	Q6920-2015
16	1	Q9003-5168
17	1	Q9007-0018
18	1	Q9007-0000

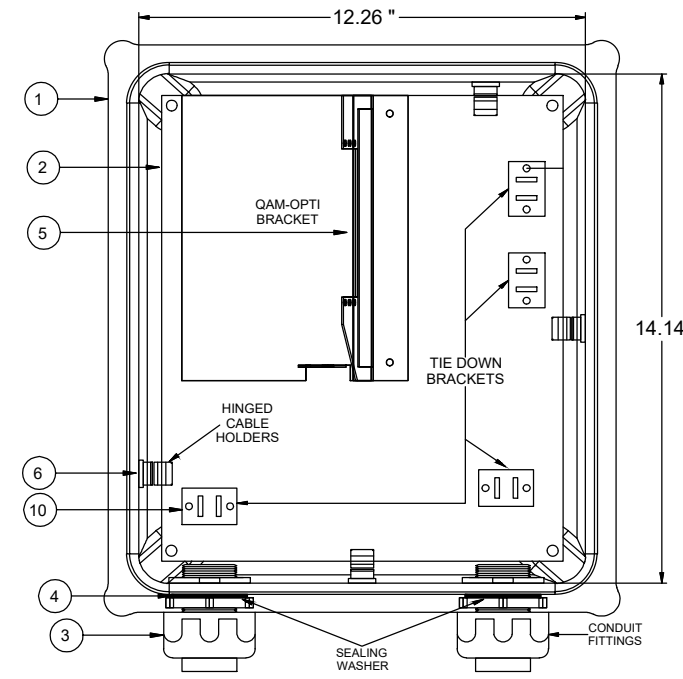

FRONT VIEW

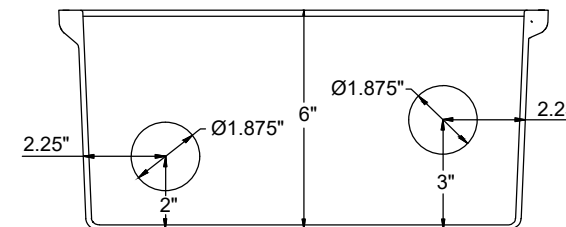

Total Weight: 16 pounds
Dimensions: 14.14" x 12.26" x 6"

BOTTOM VIEW

PREPARED FOR:



PREPARED BY:



1961 NORTHPOINT BLVD, SUITE 130
HIXSON, TN 37343
PH: 423-843-9500
FAX: 423-843-9509

DRAWING NOTICE:
THE INFORMATION CONTAINED IN THIS SET OF DOCUMENTS IS PROPRIETARY BY NATURE. ANY USE OR DISCLOSURE OTHER THAN THAT WHICH RELATES TO THE CLIENT IS STRICTLY PROHIBITED.

DRAWN BY: TMR
CHECKED BY: CTD

REVISIONS

NO.	DATE	BY	DESCRIPTION
0	10/21/21	AJD	CONSTRUCTION ISSUE
D	10/21/21	KR	PRELIMINARY REVIEW
C	07/16/21	KR	PRELIMINARY REVIEW
B	03/23/21	MJB	PRELIMINARY REVIEW
A	03/12/20	TMR	PRELIMINARY REVIEW

ENGINEER'S STAMP:



NOT VALID WITHOUT P.E. STAMP & SIGNATURE

SITE NAME: GN INDY 1324

ADDRESS: 3949 WOODMORE DR
GREENWOOD, IN 46142

COUNTY: JOHNSON

LATITUDE: 39° 37' 24.708" N

LONGITUDE: 86° 10' 31.224" W

DESIGN TYPE: RAWLAND

SHEET TITLE: EQUIPMENT DETAILS

DRAWING NO. C6
REVISION: 0

UTILITY NOTE:
1. ALL POWER CONDUITS ABOVE GRADE TO BE RIGID GALVANIZED STEEL CONDUIT.

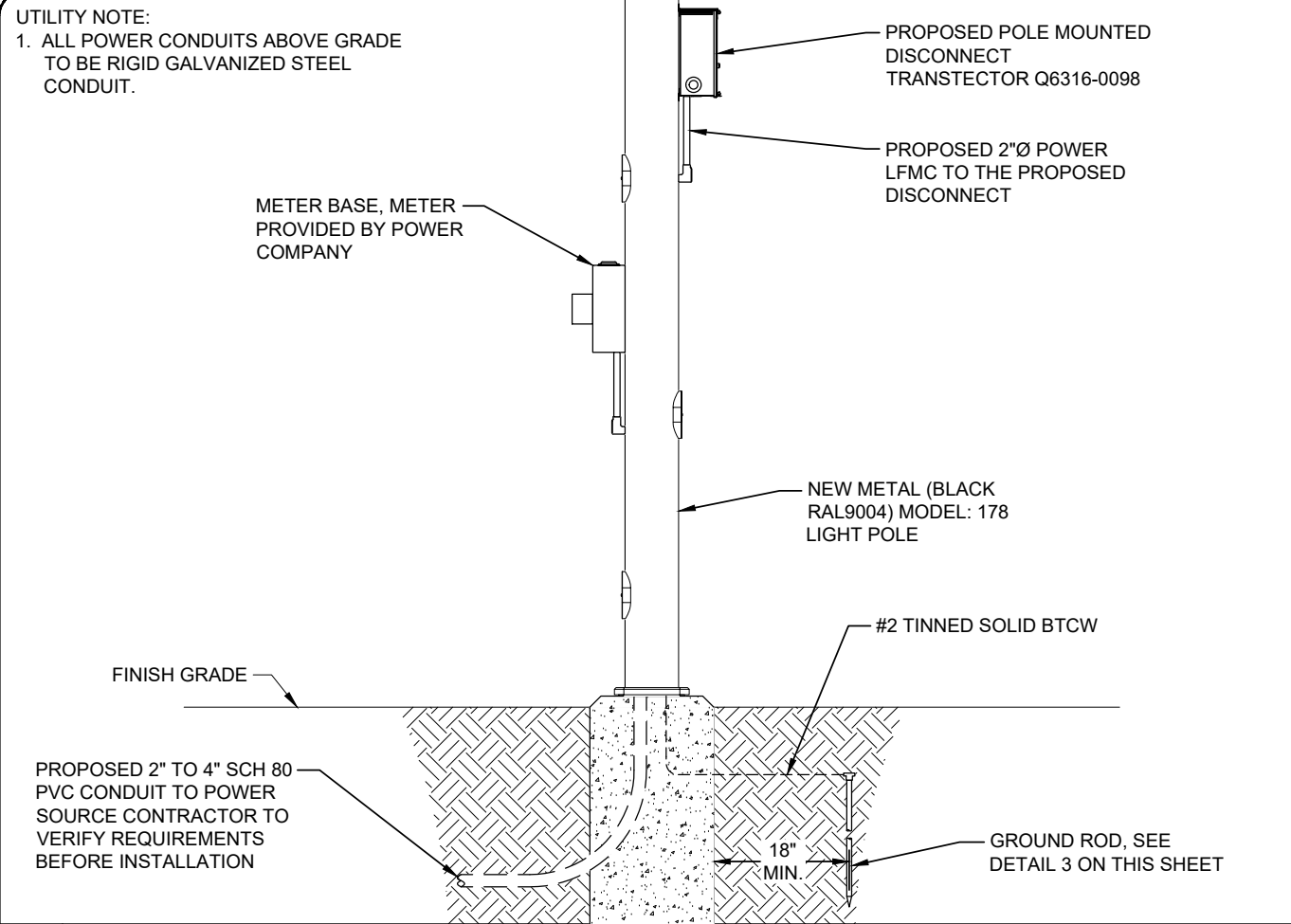

1 METER DETAIL N.T.S.

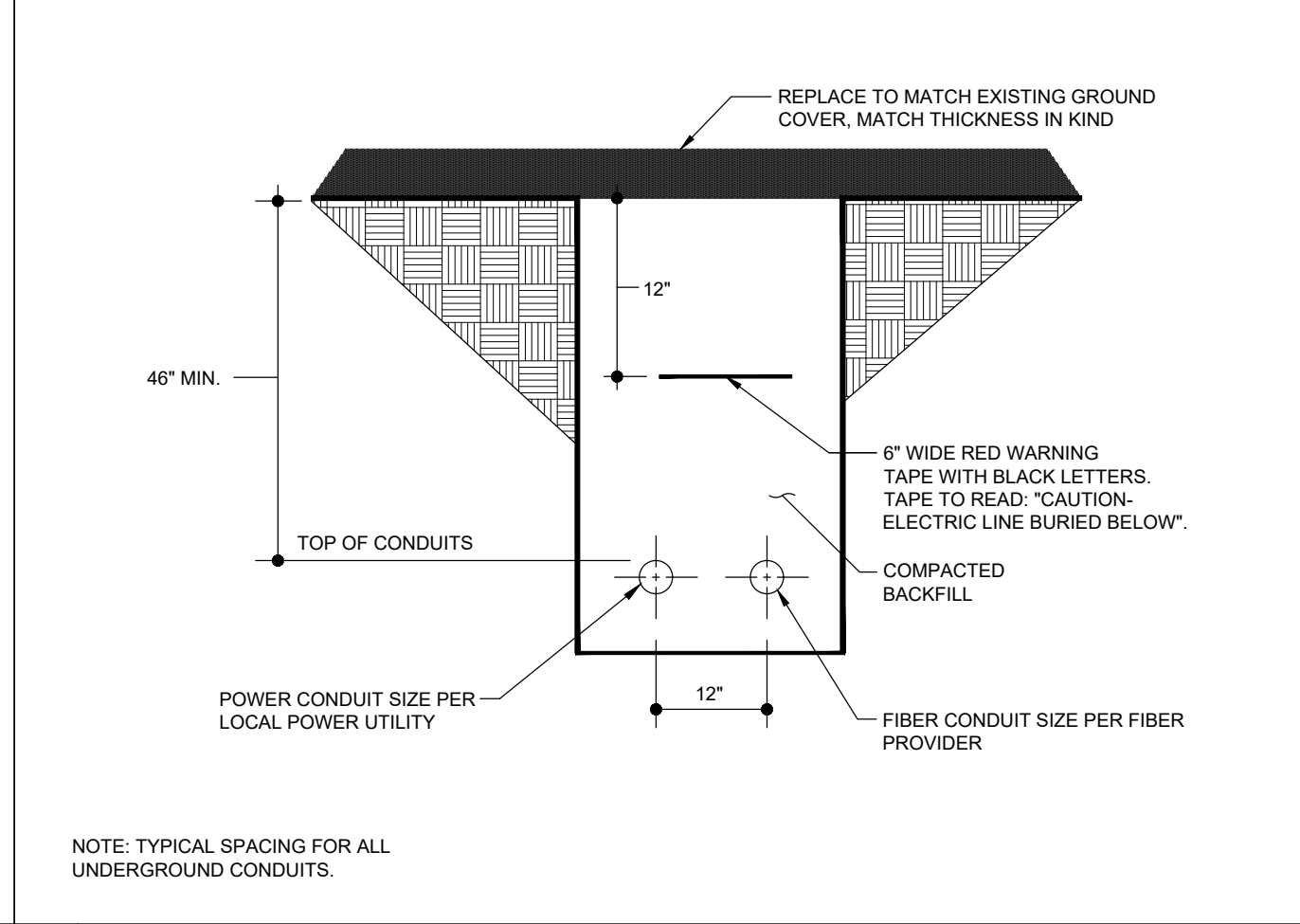

2 TRENCH DETAIL (IF REQUIRED) N.T.S.

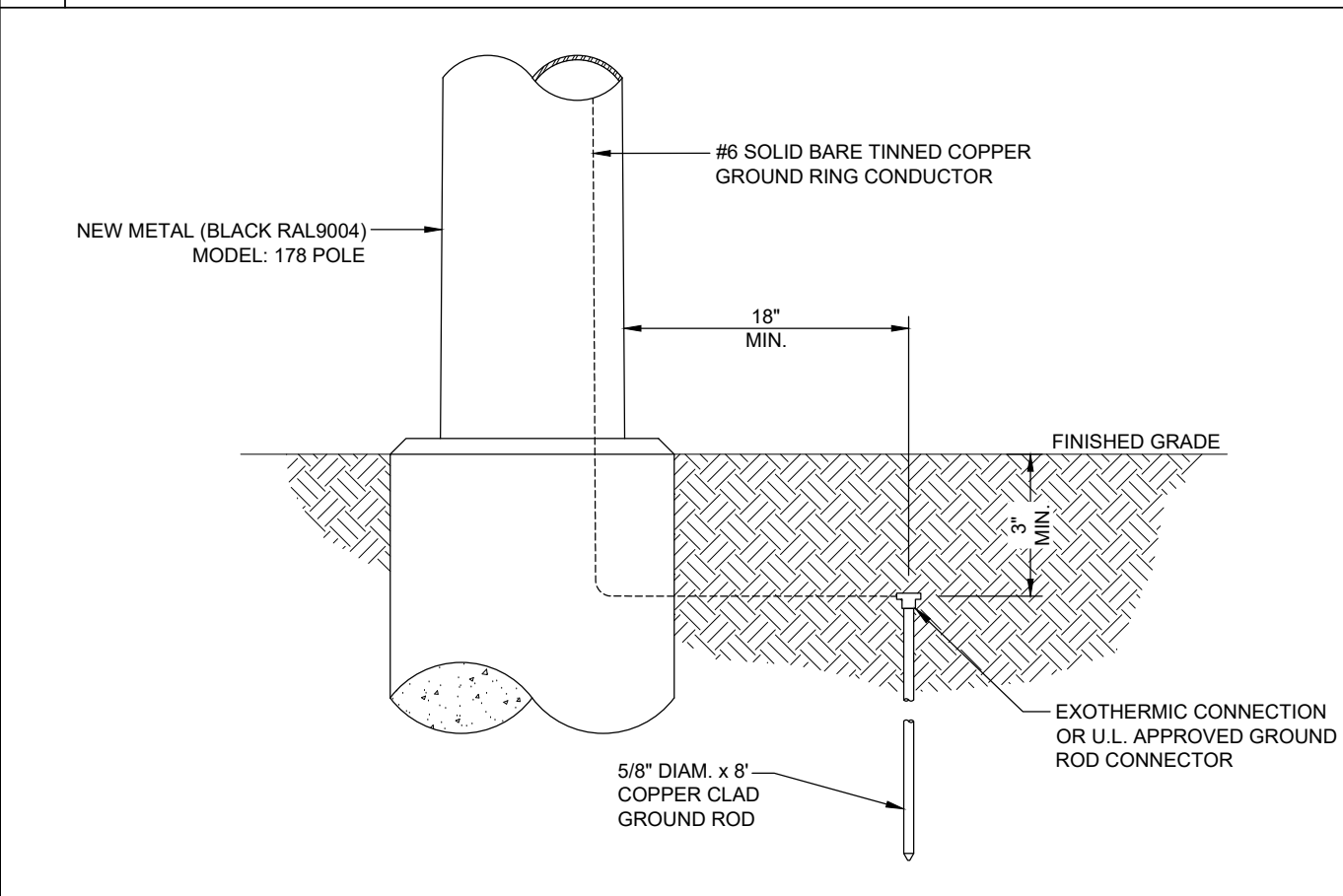

3 GROUND ROD DETAIL N.T.S.

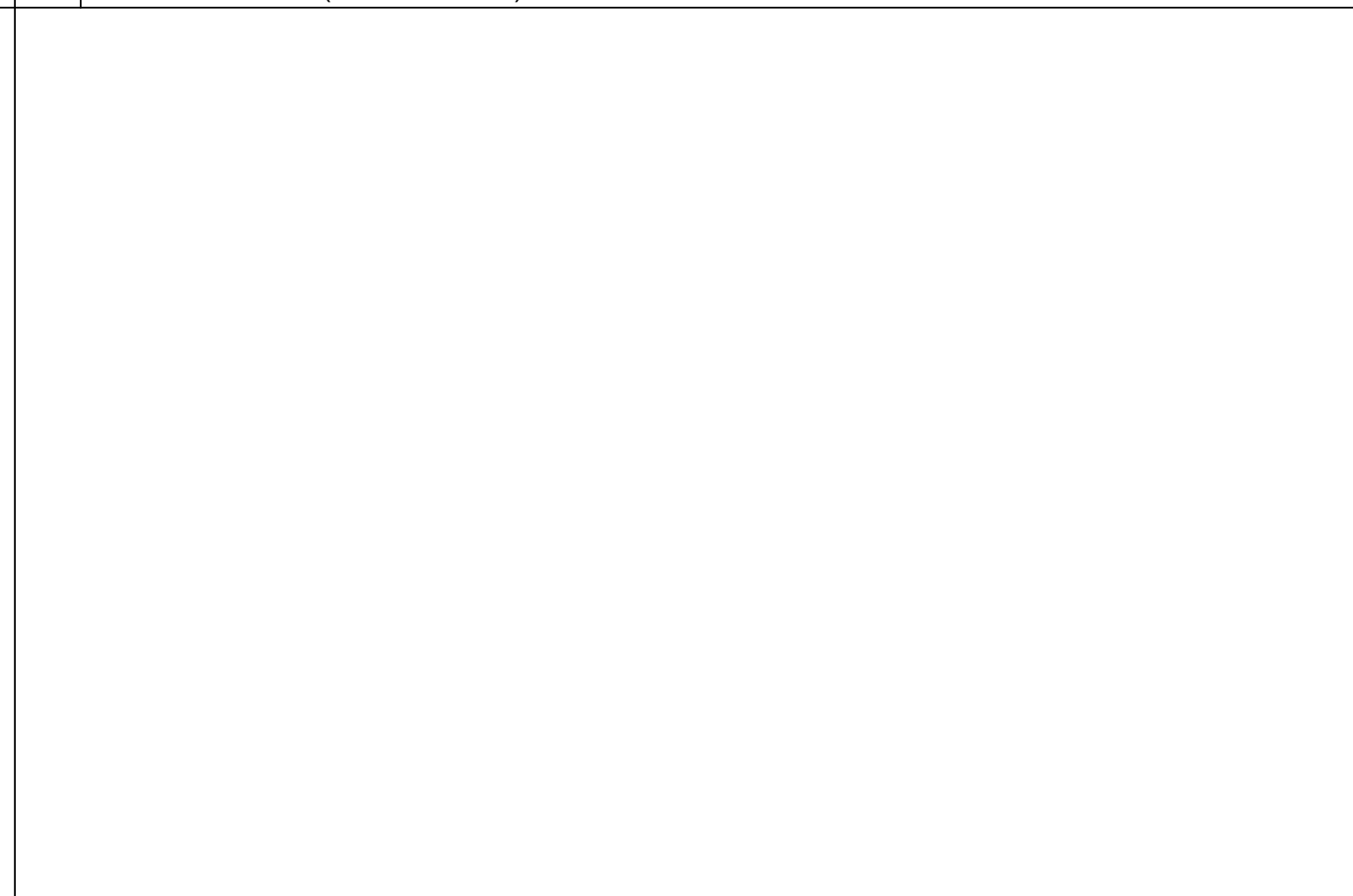

PREPARED FOR:

PREPARED BY:

1961 NORTHPOINT BLVD, SUITE 130
HIXSON, TN 37343
PH: 423-843-9500
FAX: 423-843-9509

DRAWING NOTICE:
THE INFORMATION CONTAINED IN THIS SET OF DOCUMENTS IS PROPRIETARY BY NATURE. ANY USE OR DISCLOSURE OTHER THAN THAT WHICH RELATES TO THE CLIENT IS STRICTLY PROHIBITED.

DRAWN BY: TMR
CHECKED BY: CTD

REVISIONS			
NO.	DATE	BY	DESCRIPTION
0	10/21/21	AJD	CONSTRUCTION ISSUE
D	10/21/21	KR	PRELIMINARY REVIEW
C	07/16/21	KR	PRELIMINARY REVIEW
B	03/23/21	MJB	PRELIMINARY REVIEW
A	03/12/20	TMR	PRELIMINARY REVIEW

ENGINEER'S STAMP:

NOT VALID WITHOUT P.E. STAMP & SIGNATURE

SITE NAME: GN INDY 1324

ADDRESS: 3949 WOODMORE DR
GREENWOOD, IN 46142

COUNTY: JOHNSON

LATITUDE: 39° 37' 24.708" N

LONGITUDE: 86° 10' 31.224" W

DESIGN TYPE: RAWLAND

SHEET TITLE: ELECTRICAL DETAILS

DRAWING NO. E2 REVISION: 0

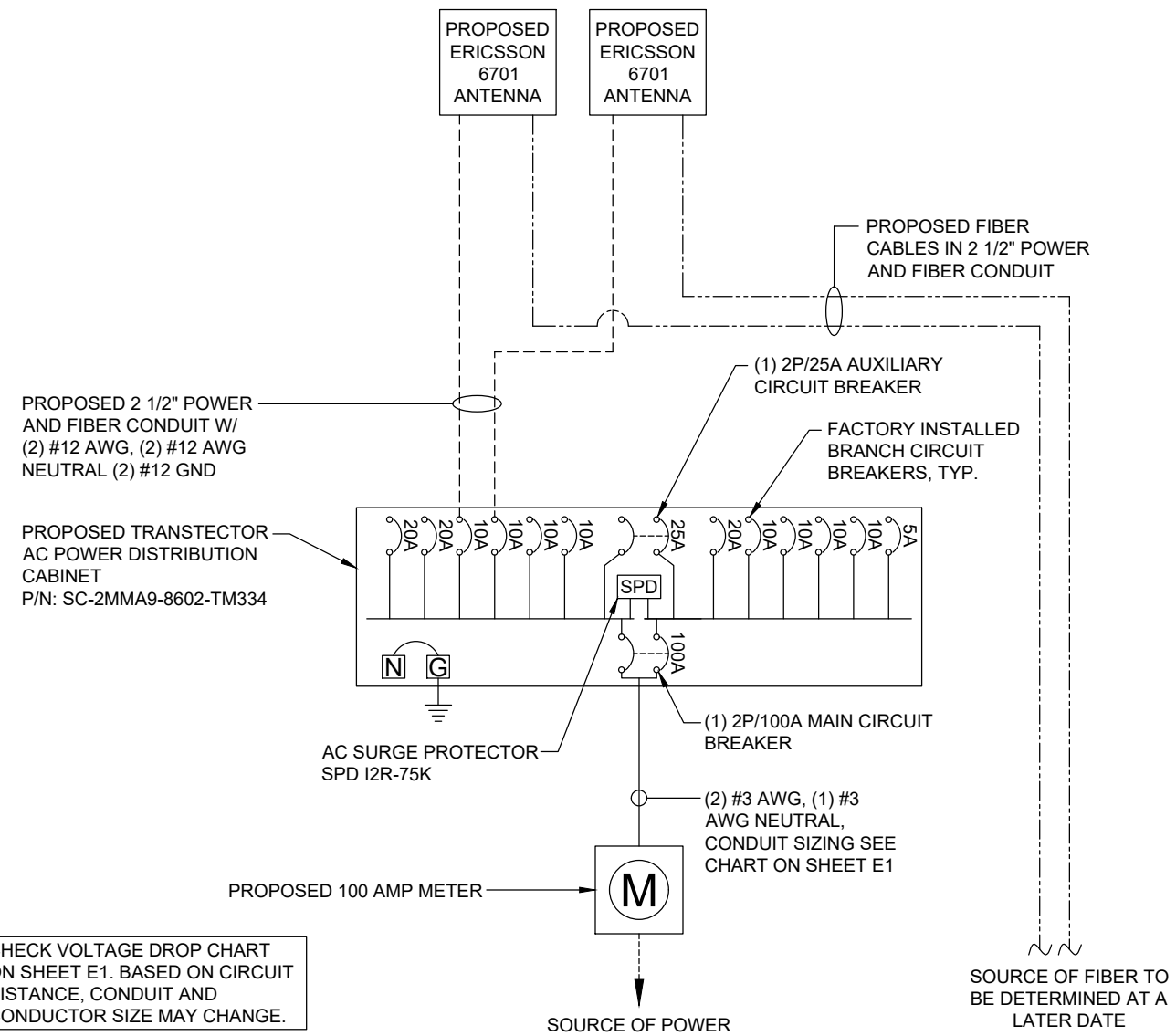

CHECK VOLTAGE DROP CHART ON SHEET E1. BASED ON CIRCUIT DISTANCE, CONDUIT AND CONDUCTOR SIZE MAY CHANGE.

PREPARED FOR:



PREPARED BY:

TeleCAD
Wireless

1961 NORTHPOINT BLVD, SUITE 130
HIXSON, TN 37343
PH: 423-843-9500
FAX: 423-843-9509

DRAWING NOTICE:
THE INFORMATION CONTAINED IN THIS SET OF DOCUMENTS IS PROPRIETARY BY NATURE. ANY USE OR DISCLOSURE OTHER THAN THAT WHICH RELATES TO THE CLIENT IS STRICTLY PROHIBITED.

DRAWN BY: TMR
CHECKED BY: CTD

REVISIONS

NO.	DATE	BY	DESCRIPTION
0	10/21/21	AJD	CONSTRUCTION ISSUE
D	10/21/21	KR	PRELIMINARY REVIEW
C	07/16/21	KR	PRELIMINARY REVIEW
B	03/23/21	MJB	PRELIMINARY REVIEW
A	03/12/20	TMR	PRELIMINARY REVIEW

ENGINEER'S STAMP:



NOT VALID WITHOUT P.E. STAMP & SIGNATURE

SITE NAME: GN INDY 1324

ADDRESS: 3949 WOODMORE DR
GREENWOOD, IN 46142

COUNTY: JOHNSON

LATITUDE: 39° 37' 24.708" N

LONGITUDE: 86° 10' 31.224" W

DESIGN TYPE: RAWLAND

SHEET TITLE: SINGLE LINE DIAGRAM

DRAWING NO. E3

REVISION: 0

PREPARED FOR:



PREPARED BY:



1961 NORTHPOINT BLVD, SUITE 130
HIXSON, TN 37343
PH: 423-843-9500
FAX: 423-843-9509

DRAWING NOTICE:
THE INFORMATION CONTAINED IN THIS SET OF DOCUMENTS IS PROPRIETARY BY NATURE. ANY USE OR DISCLOSURE OTHER THAN THAT WHICH RELATES TO THE CLIENT IS STRICTLY PROHIBITED.

DRAWN BY: TMR
CHECKED BY: CTD

REVISIONS

NO.	DATE	BY	DESCRIPTION
0	10/21/21	AJD	CONSTRUCTION ISSUE
D	10/21/21	KR	PRELIMINARY REVIEW
C	07/16/21	KR	PRELIMINARY REVIEW
B	03/23/21	MJB	PRELIMINARY REVIEW
A	03/12/20	TMR	PRELIMINARY REVIEW

ENGINEER'S STAMP:

FOR REFERENCE ONLY

NOT VALID WITHOUT P.E. STAMP & SIGNATURE

SITE NAME: GN INDY 1324

ADDRESS: 3949 WOODMORE DR
GREENWOOD, IN 46142

COUNTY: JOHNSON

LATITUDE: 39° 37' 24.708" N

LONGITUDE: 86° 10' 31.224" W

DESIGN TYPE: RAWLAND

SHEET TITLE: FOUNDATION DESIGN

DRAWING NO. **S3** REVISION: **0**

ITEM NO.	QTY.	Description	Weight (lbs)
1	1	4500 psi Concrete Caisson	4091.6
2	8	#6 Grade 60 Vertical Steel Reinforcement Bar	12.3
3	16	#3 Grade 60 Steel Ties	1.7
4	1	Anchor Cage	68.15
5	4	2in PVC Conduit	2.22

SITE ADDRESSES
State of Indiana

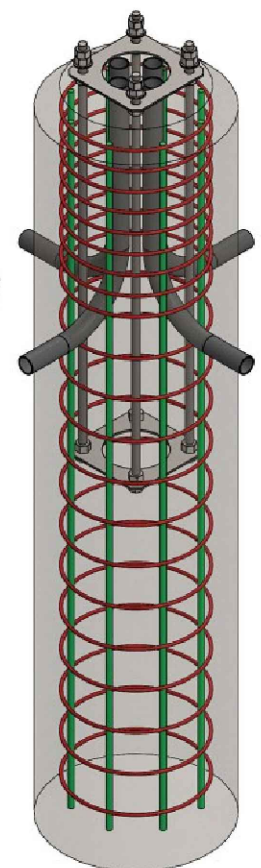
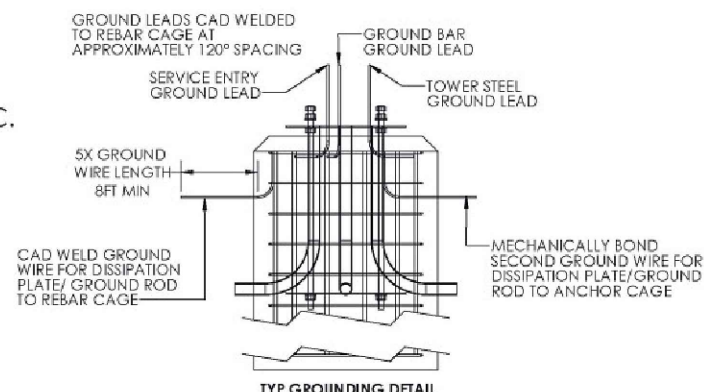
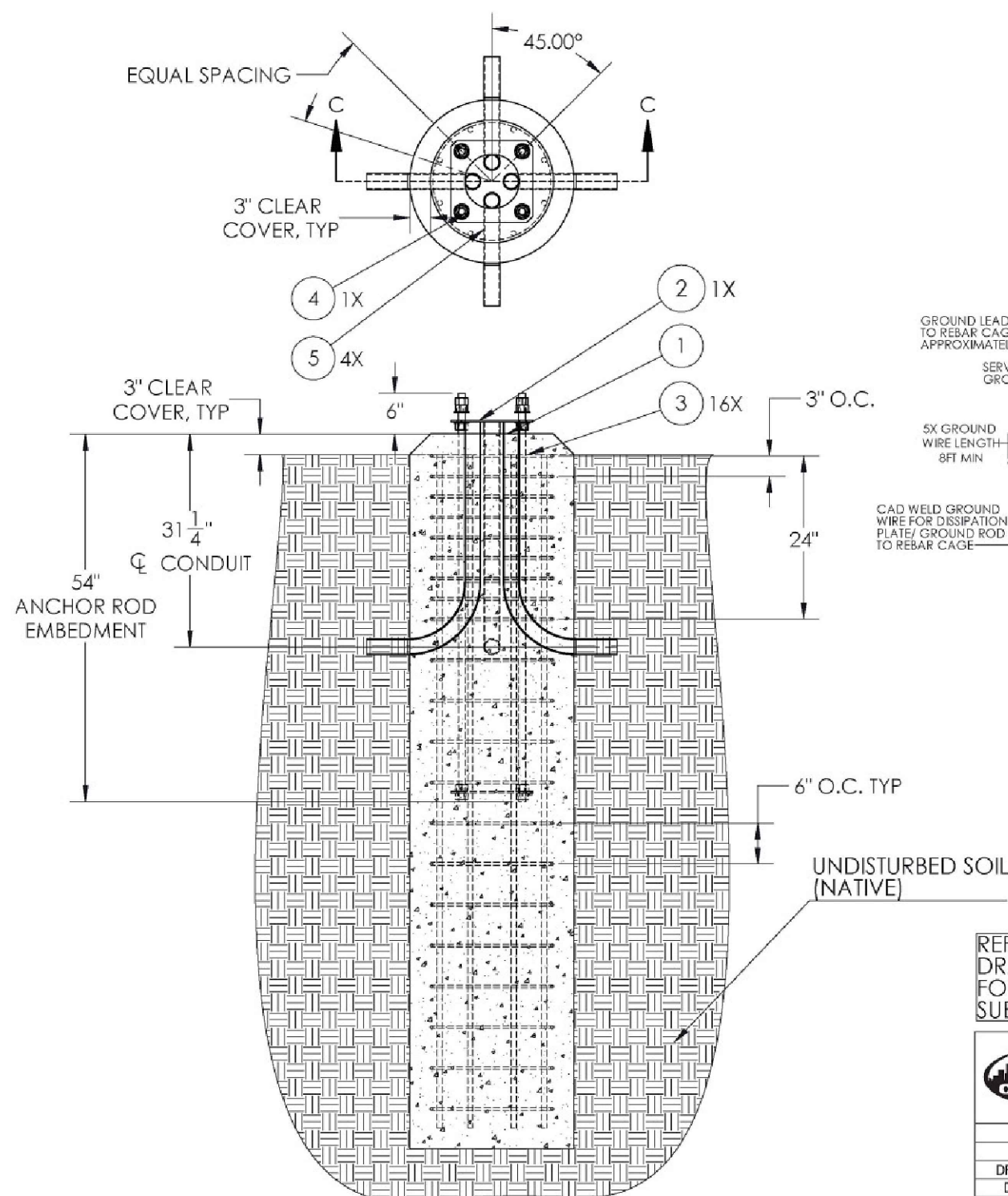

REFER TO CONSTRUCTION DRAWINGS (BY OTHERS) FOR ADDITIONAL SUBGRADE REQUIREMENTS

CityPole logo
www.comptektechnologies.com
5555 CENTRAL AVE, SUITE 100
BOULDER CO. 80301
PH: 303.531.5758
FAX: 303.531.5595

FINISH	UNIT FORMAT	DESCRIPTION
FT-IN-LBS		8IN SMALL CELL POLE FND
DRW BY: DAC	APPR BY: MPA	ENG BY: MS
PROJECT. NO.		PART NO.

30596

Copyright 2019 by Comptek, all rights reserved. This drawing is loaned for mutual assistance and as such is subjected to recall at any time. Information contained herein is not to be disclosed or reproduced in any form for the benefit of parties other than subcontractors and suppliers without written consent of Comptek Technologies INC.

REV.	BY	DATE	APPR	REVISION DESCRIPTION
01	DAC	10/16/19	MPA	INITIAL RELEASE
02	DAC	7/27/20	MPA	UPDATED NOTES

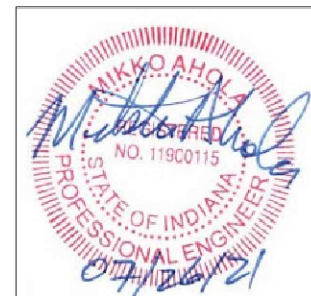

MIKKO P. AHOLA, P.E.
INDIANA PROFESSIONAL ENGINEER
LICENSE #PE11900115 (EXP. 07/31/2020)

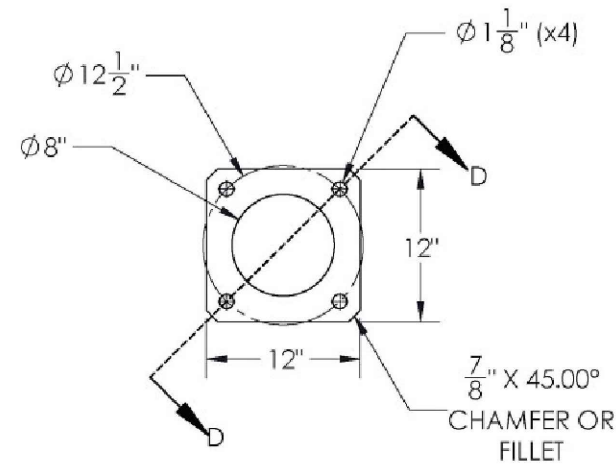

TEMPLATE RING PLAN

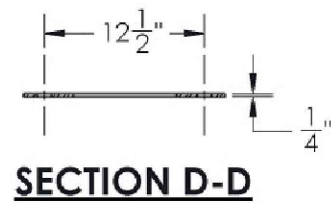

ITEM NO.	DESCRIPTION	QTY.	SITE ADDRESSES
1	HARDENED WASHERS 436 HDG	8	State of Indiana
2	1" HEX NUT HDG	20	
3	1"x60" A 193 B7 threaded Rods HDG	4	
4	8IN POLE TEMPLATE RING	2	

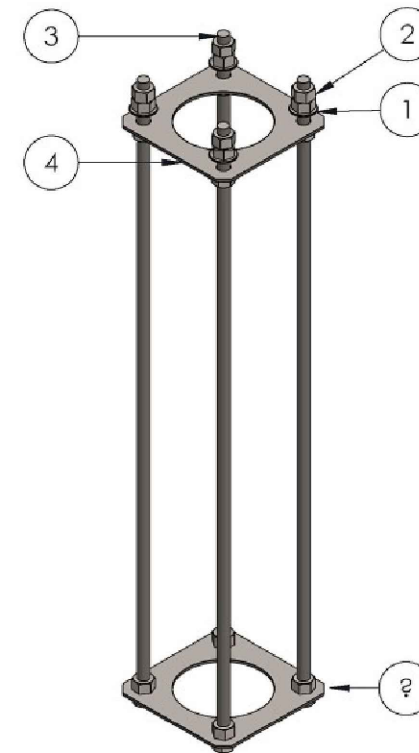

ANCHOR CAGE ASSEMBLY ISOMETRIC

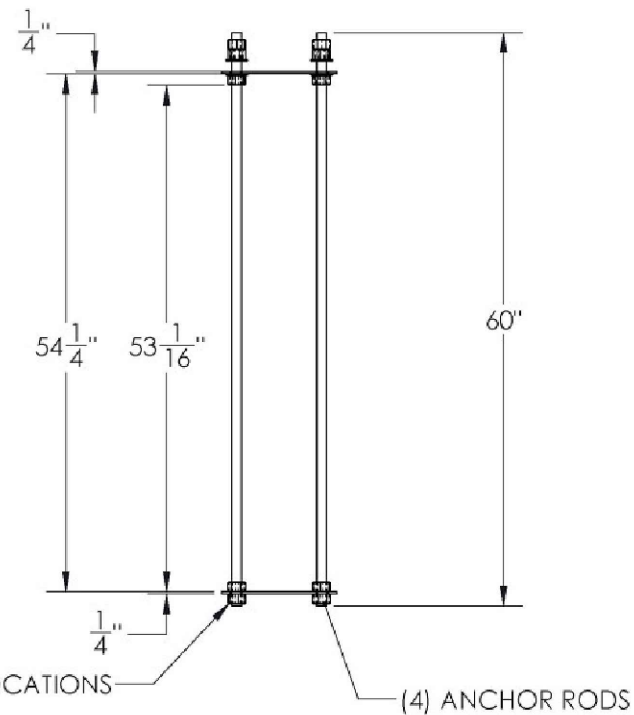

ANCHOR CAGE ASSEMBLY ELEVATION

MIKKO P. AHOLA, P.E.
 INDIANA PROFESSIONAL ENGINEER
 LICENSE #PE11900115 (EXP. 07/31/2020)

		www.comptektechnologies.com 5555 CENTRAL AVE, SUITE 100 BOULDER CO. 80301 PH: 303.531.5758 FAX: 303.531.5595		REVISION	
REV.	BY	DATE	APPR.	REVISION DESCRIPTION	
01	DAC	10/16/19	MPA	INITIAL RELEASE	
02	DAC	7/27/20	MPA	UPDATED NOTES	
FINISH UNIT FORMAT DESCRIPTION FT-IN-LBS 8IN SMALL CELL POLE FND					
DRW BY	APPR BY	ENG. BY	PART NO.		
DAC	MPA	MS			
PROJECT. NO.			REV.		
30596			02		

PREPARED FOR:

PREPARED BY:

1961 NORTHPOINT BLVD, SUITE 130
 HIXSON, TN 37343
 PH: 423-843-9500
 FAX: 423-843-9509

DRAWING NOTICE:
 THE INFORMATION CONTAINED IN THIS SET OF DOCUMENTS IS PROPRIETARY BY NATURE. ANY USE OR DISCLOSURE OTHER THAN THAT WHICH RELATES TO THE CLIENT IS STRICTLY PROHIBITED.

DRAWN BY: TMR
 CHECKED BY: CTD

REVISIONS			
NO.	DATE	BY	DESCRIPTION
0	10/21/21	AJD	CONSTRUCTION ISSUE
D	10/21/21	KR	PRELIMINARY REVIEW
C	07/16/21	KR	PRELIMINARY REVIEW
B	03/23/21	MJB	PRELIMINARY REVIEW
A	03/12/20	TMR	PRELIMINARY REVIEW

ENGINEER'S STAMP:

FOR REFERENCE ONLY

NOT VALID WITHOUT P.E. STAMP & SIGNATURE

SITE NAME: GN INDY 1324

ADDRESS: 3949 WOODMORE DR
 GREENWOOD, IN 46142

COUNTY: JOHNSON

LATITUDE: 39° 37' 24.708" N

LONGITUDE: 86° 10' 31.224" W

DESIGN TYPE: RAWLAND

SHEET TITLE: FOUNDATION DESIGN

DRAWING NO. **S4** REVISION: **0**

GN INDY 1324 – 39.62353 -86.17534

Site Type: VZW - NEW METAL POLE WITH LIGHT

ROW: Woodmore Dr.

Nearest Intersection: Woodmore Dr. and Woodmore Ct.

Nearest Address: 3953 Woodmore Dr.

City: Greenwood.

Zip Code: 46142

E911 Address: 3949 WOODMORE DR, GREENWOOD, IN 46142

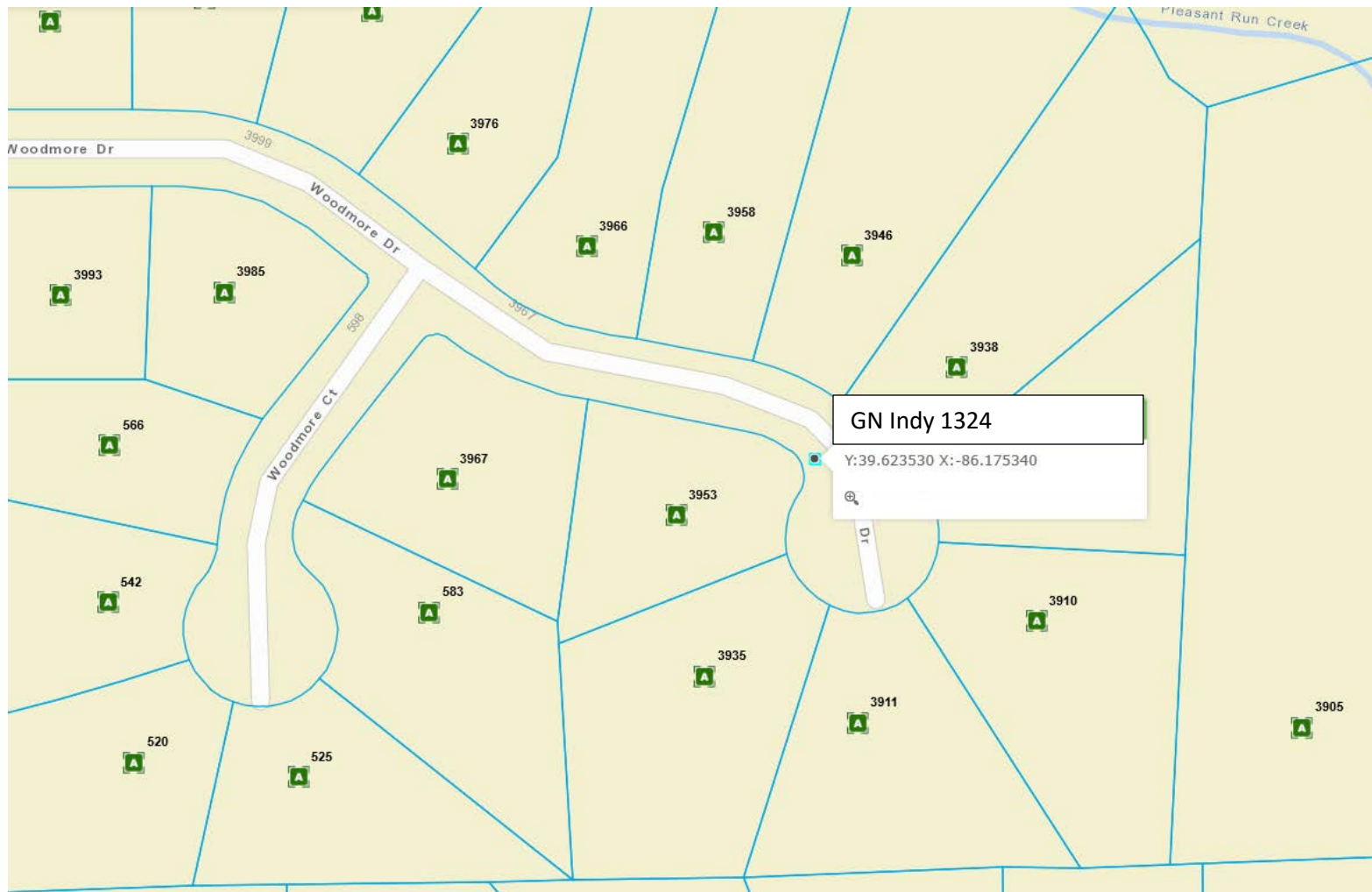

FINDINGS OF FACT, DEVELOPMENT STANDARDS VARIANCE

JOHNSON COUNTY BOARD OF ZONING APPEALS

1. The approval will not be injurious to the public health, safety, morals and general welfare of the community because:

2. The use and value of the area adjacent to the property included in the variance will not be affected in a substantially adverse manner because:

3. The strict application of the terms of the Zoning Ordinance will result in practical difficulties in the use of the property because:

FINDINGS OF FACT, SPECIAL EXCEPTION

JOHNSON COUNTY BOARD OF ZONING APPEALS

1. The use shall be specifically identified as a special exception in this Ordinance for the zoning district in question because:

2. The special exception can be served with adequate utilities, access roads, drainage and other necessary facilities because:

3. The special exception shall not involve any element or cause any condition that may be dangerous, injurious or noxious to any other property or persons, and shall comply with any and all design development standards for the use identified in this Ordinance because:

4. The special exception shall be sited, oriented and landscaped to produce a harmonious relationship of buildings and grounds to adjacent buildings and property because:

5. The special exception shall produce a total visual impression and environment which is consistent with the environment of the neighborhood because:

6. The special exception shall organize vehicular access and parking to minimize traffic congestion in the neighborhood because:

7. The special exception shall preserve the purpose of this Ordinance, and shall not interfere substantially with the Comprehensive Plan because:

ON-SITE NOTICE REFUNDABLE DEPOSIT FORM

JOHNSON COUNTY DEPARTMENT OF PLANNING AND ZONING

On-Site Public Notice Sign Instructions

1. The applicant must provide a \$25.00 deposit (via cash, check or credit/debit card) to the Department of Planning and Zoning for each required on-site public notice sign, which will be provided by the Department of Planning and Zoning.
2. The land use petitioner must display the sign along the subject property's street frontage, so that the sign is prominent and readable from the adjoining street. If the subject lot is especially large or adjoins more than one street, staff may require placement of additional on-site signs.
3. The sign(s) must be posted on site at least 21 calendar days prior to the scheduled hearing, and must remain posted until the associated land use petition has been fully resolved.
4. The applicant must return the sign(s) to the Department of Planning and Zoning in good condition within 30 days of completion of the land use petition to be eligible for a full refund. The refund will be mailed to the petitioner within a maximum of 4 weeks of the return of the sign(s).

I have read and understand the above instructions and requirements regarding the posting of required on-site public notice signage, and have paid the required refundable deposit.

David M Bates - TeleCAD Wireless - on behalf of Verizon Wireless



Petitioner/Representative Signature

Date

Case Number (Office Use)

AFFIDAVIT OF NOTICE OF PUBLIC HEARING

JOHNSON COUNTY DEPARTMENT OF PLANNING AND ZONING

This form must be completed and submitted to the Department of Planning and Zoning no later than the Friday prior to hearing.

I/we, _____, do hereby certify that notice of public hearing by the Board of Zoning Appeals of Johnson County to consider Case Number _____ was mailed by *certificate of mailing* to the persons identified on the attached list, and that these persons, who were included in the most recent and current records of the Johnson County Mapping Department, represent all those required to be notified of this petition.

Please attach the list of addresses provided by the Department of Planning & Zoning.

Said notices of public hearing were mailed by certificate of mailing on or before (*mailing date*) _____, 20 ____, being at least 21 days prior to (*hearing date*) _____, 20 ____, the date of the Public Hearing.

I/we further hereby certify that the required public notice sign was posted in a conspicuous place on the subject property on (*date*) _____, 20 ____, also being at least 21 days prior to the scheduled public hearing.

The above information, to my knowledge and belief, is true and correct.

Signature of Petitioner

State of Indiana)
) SS:
County of)

Subscribed and sworn to before me this _____ day of _____,

My commission expires: _____

Notary Public

County of Residence: _____