

Municipal Plat

(Petition for all Plats, Projects and Commercial Sites
Within Other Municipalities)

Johnson County Surveyor's Office Johnson County Drainage Board Application Packet



1. Fees & Deadlines
2. Application Forms
3. Documents & Exhibits
4. Review
5. Notice
5. Procedures & Hearings
6. Calendar, Examples

June 19, 2023

Johnson County Surveyor
86 West Court Street, Franklin, Indiana 46131

1. **Fees** \$375.00 *Make checks payable to Johnson County Drainage Board)*

Application Filing Fee, \$375.00. Fee includes 1 hour of review time, all other review time is subject to a \$200.00 hourly charge. If additional review fees are charged on an hourly basis, applicants / owners will be billed, and invoices are due within 30 days of invoice.

Note: Fees for Outlet and Encroachment are not included. If an Outlet and/or Encroachment is needed, applicant must submit those applications.

Also see, Johnson County Drainage Board Petition for Establishment of New Regulated Drain (IC 36-9-27-54).

1. **Deadlines**

Petition must be heard by the applicable Technical Review Committee (city /town) prior to being placed on JCDB (Johnson County Drainage Board) Agenda. JCDB petitions, and those of area municipalities will not necessarily align in either type of petition, or technical information needed at each stage of petition.

Filing deadline is approximately 30 days prior to drainage board meeting. Drainage Board Secretary prepares an annual schedule, or **Calendar of Meetings**. This schedule of approved filing deadlines, and drainage board meeting dates, is typically available after the December drainage board meeting. Hearing dates are not guaranteed.

If filing deadline falls on a day that the county offices are closed the date shall be forwarded to the next business day. All applications / petitions are due between 8am- 12pm & 1pm- 4pm, including those mailed or delivered.

County surveyor reserves the right to move applications and petitions to the next available meeting night when additional review time is needed, meeting agenda is full, or other scheduling conflicts necessitate.

1b. **Proof of Notification**

(Rules of Procedure, Article 7, Notice Requirements, Sec. 1-4)

2. Application / Petition

Within City or Town of _____

Each petition to the Board shall be filed in the office of the Surveyor and be on application forms approved by the Board. They shall be accompanied by such information and exhibits as specified on such forms and/or required by applicable ordinances. Any communication purporting to be a petition not on the prescribed forms or not containing the information required shall be considered incomplete and shall not be docketed. Any application which is incomplete at the time of the filing deadline shall not be docketed.

APPLICATION FOR DRAINAGE BOARD REVIEW DATE FILED: _____

PROJECT NAME: _____

PETTITIONER and AGENT: _____

Address: _____

EMAIL: _____ PHONE: _____

REQUESTED HEARING DATE: _____

TYPE OF PLAT OR SITE PLAN: _____

ADDITIONAL REQUESTS (Outlet / Encroach): _____

SITE ADDRESS: _____

ACREAGE _____ SECTION _____ TOWNSHIP _____ RANGE _____

FOR **JOHNSON COUNTY , DRAINAGE BOARD USE ONLY**

DOCKET NUMBER _____ FEE: _____

Approved _____ Denied _____ Continued _____

7 COPIES OF SKETCH PLAN _____ PDF _____

7 COPIES OF SITE PLANS _____ PDF _____

2 COPIES OF DRAINAGE CALCULATIONS _____ PDF _____

PROOF OF MAILING _____

PROOF OF NEWSPAPER NOTIFICATION _____

REVIEW ENGINEER _____

2. AFFIDAVIT OF CONSENT AND RESPONSIBILITY
OF PROPERTY OWNER

I (we) _____ and after being first duly sworn, depose and say:

(A.) That I/we are the owner(s) of the real estate located at:

SITE ADDRESS: _____

ACRAGE _____ SECTION _____ TOWNSHIP _____ RANGE _____

- (B.) That I/we have read and examined the Petition Application, and are familiar with its contents.
- (C.) That I / we have no objections to and consent to such request as set forth in the petition application.
- (D.) That such being made by the Petitioner is/ is not a condition to the sale or lease of the above referenced property.
- (E.) Owner agrees to pay all sums necessary for the compensation of an independent engineer who is providing engineering services to the county surveyor for development plan review.
- (F.) In the event Applicant is not the sole proprietor, the person signing in its behalf, and hereby represents and warrants that this organization has taken the appropriate action to authorize his or her signature on this document.
- (G.) Owner, or Applicant on owners behalf shall pay for the additional review time at the rate of \$200.00 per hour upon receiving the county surveyors invoice for time and expense of project review.

Owner _____

Owner _____

SEAL

Notary, State of Indiana

Subscribed and sworn to before me this _____ day of _____

My Commission expires: _____ County of Residence: _____

Signature of Notary: _____

Printed name of Notary _____

3. Support Documents, Surveys, Plats, Plans, and Drainage Reports

Each application / petition to the drainage board shall be filed, in person, in the office of the county surveyor, at the appropriate place and time, and be on supplied forms approved by the county surveyor. They shall be accompanied by such information, reports, calculations, and exhibits as forms specify, or required by ordinances, and procedures. Any communication, or informal requests purporting to be a petition not on the prescribed forms or not containing adequate information required, shall be considered incomplete and may not be docketed, at the discretion of the county surveyor, or board. Any application which is incomplete at the time of filing deadline shall not be docketed. All applications / petitions are fluid, additional time maybe required for review, or the types of applications my limit the meeting agenda.

Support documentation shall include, but not be limited to:

1. Seven (7) Paper Copies*, of which five (5) of the said sets can be reduced (11x17).
2. One copy of Drainage Report & Calculations (paper).
3. A copy of all application forms, plans, plats, and supporting documents in a PDF format, on CD, PD (portable drive), or a downloadable site format emailed to: creynolds@co.johnson.in.us and copied to: gcantwell@co.johnson.in.us

Office Location:

Johnson County Surveyors Office
Johnson County Drainage Board
86 West Court Street
Franklin, Indiana 46131
Phone: 317-346-4343
Email: gcantwell@co.johnson.in.us

Office Receiving Hours: Monday- Friday, 8am-12 Noon, & 1pm- 4pm

* Paper Copies refer to Sketch Plan, Survey, Plat, Construction Plans, or other large format support documentation.

4. Review

Petition must be heard by the applicable Technical Review Committee (city /town) prior to being placed on JCDB (Johnson County Drainage Board) Agenda. JCDB petitions, and those of area municipalities will not necessarily align in either type of petition, or technical information needed at each stage of petition.

Owner / petitioner agrees to pay all sums necessary for the compensation of an independent or staff engineer who is providing engineering services to the county surveyor for development plan review. Owner, or applicant on owners behalf shall pay for the additional review time at the rate of \$200.00 per hour upon receiving the county surveyors invoice for time and expense of project review.

County surveyor reserves the right to move applications and petitions to the next available meeting night when additional review time is needed, meeting agenda is full, or other scheduling conflicts necessitate.

5. Notice

Notice by publication containing all necessary information shall be given by the petitioner in a newspaper of general circulation in Johnson County (**Daily Journal**), at least ten calendar days before the hearing, and proof of publication shall be made by an affidavit of the publisher attached to a copy of the notice taken from the newspaper in which it was taken and filed with the Board. Such affidavit shall specify the county, the time of publication, and the paper in which the notice was published. The petitioner shall assume the cost of said publication. Proof of such publication shall be provided to the Drainage Board secretary prior to meeting, by petitioner to be kept in the appropriate file.

Mailing of Notice shall be given to owners of all property within a distance of **six hundred feet or two property owners**, whichever is greater, from the boundaries of the affected property. Notification by **certificate of mail** shall be sent not less than ten calendar days prior to the hearing, with said notice containing the following information: **a.** Docket number and the substance of the matter to be heard. **b.** General location by mailing address, township, and recorded legal description of the property. **c.** Name of the person or agency initiating the matter to be heard. **d.** Time, Date, and place of hearing. **e.** Statement that the petition may be examined at the office of the County Surveyor. **f.** Statement that interested parties may offer an oral opinion at the hearing or may file written comments concerning the matter to be heard to or at the hearing. **g.** Information regarding access or alternative participation (Zoom, FB, etc..). **e.** Any other information, which may be required by law to be contained in such notice. Certified mail receipts and notarized affidavits listing the names and addresses of the property owners and proof of service of said notice shall be considered evidence that notice has been given. Personal appearance at the hearing shall constitute evidence of notice. (Return receipts to be presented to Board secretary prior to meeting).

RULES OF PROCEDURE
JOHNSON COUNTY DRAINAGE BOARD
ARTICLE I AUTHORITY, DUTIES

Section 1. Authority

The Johnson County Drainage Board (hereinafter called "Board") exists under authority of Indiana Code 36-9-27-4, and all acts supplemental and amendatory thereto.

Section 2. Duties

The Duties of the Johnson County Drain Board shall be those set forth in IC 36-9-27-1, et seq, "DRAINAGE LAWS" and such other responsibilities as may be adopted by the Board.

Section 3. Membership

The Board shall consist of three or five members in accordance with IC 36-9-27-5.

Section 4. Meetings

All meetings of the Board shall be conducted in accordance with IC-36-9-27-7, The Indiana Open Door Law, and any amendments thereto. On-site inspections of property involved in petitions before the Board shall not be considered meetings.

a. Regular meetings - The Board shall hold a regular meeting on the first Tuesday of each month. Whenever the regular meeting date falls on an official holiday or precedes Election Day, another date shall be selected. A schedule of all regular meetings shall be published each year. All regular meetings shall be held in the public hearing room of the Johnson County Annex at the times designated on the schedule of meetings, unless otherwise designated by the Board.

b. Special Meetings - In accordance with the provision of IC 36-9-27-7(d), special meetings of the Board may be called at any time by the Chairman, any two (2) members, or the county surveyor, by mailing a written notice setting forth the time, date, and place of the meeting to each member not less than five (5) days before the date of the meeting. A member may waive the mailing of notice of a special meeting by filing a written waiver with the secretary or by his presence at the meeting.

c. Cancellation - Whenever there is a lack of business for Board consideration, the Chairman may dispense with a regular meeting. In such case, the secretary of the Board shall give written notice of all members, and the news media shall be notified of such a cancellation. Whenever it is determined that a quorum is not available for a regular or special meeting, the Chairman of the Board shall dispense with such meeting, and all business scheduled for such meeting will be automatically continued to the next regular or special meeting. In such cases, the secretary of the Board shall give written or oral notice to the Board members, those having business before the Board, and to the news media. The Chairman of the Board also may dispense with a scheduled regular or special meeting in the event of a natural disaster, snow emergency, or similar causes. In such cases, the secretary of the Board shall give written or oral notice to the Board members and those having business before the Board if possible, and the secretary notify the news media of the cancellation. In the event of cancellation for any reason, the Chairman may require re-notification to interested parties, with such notice to be paid for by the petitioner or by the Board, as the Chairman deems appropriate.

ARTICLE II OFFICERS AND RECORDING SECRETARY

Section 1. Board Officers

In accordance with IC 36-9-27-7(a), at its first regular meeting of each year, the Board shall elect from its members a Chairman, Vice Chairman, and Secretary. The Board shall appoint a recording secretary, and an attorney.

Section 2. Duties of Board Officers

a. Chairman - The Chairman shall preside over Board meetings and on behalf of the Board shall exercise general supervision over the affairs of the Board, the appointment of committees and representatives, and determination of points of order and procedure, and the signing of all official documents.

b. Vice Chairman - The Vice Chairman shall have authority to act as Chairman of the Board during the absence or disability of the Chairman.

c. Secretary - The Secretary shall certify all official acts of the Board and in the absence of either the Chairman or the Vice Chairman, the Secretary shall preside, provided, however, the first and only item of business to be presented by such presiding officers shall be the election of a Chairman pro tempore. In the event of the absence or disability of the Secretary, the Chairman of the Board shall select a Secretary pro tempore.

d. Directives - Any policies or assignments to the secretary not covered by these regulations shall be by resolution of the Board.

ARTICLE III CONDUCT OF MEETINGS

Section 1. Quorum

A majority of the voting members of the board constitutes a quorum, and the concurrence of a majority of the voting members present at a meeting is necessary to authorize any action under this chapter.

Section 2. Voting

a. Majority - No action of the Board is official unless it is authorized at a regular or special meeting by a majority of the voting members present at the meeting.

b. Conflict of interest - In accordance with IC 36-9-27-12, whenever it appears, in any proceeding for the construction, reconstruction, or maintenance of a regulated drain, that a member of the board has an interest in the proceedings because of his ownership of real property affected by the drain, that member shall immediately disqualify himself from serving on the board in those proceedings. However, the fact that county highways will be affected by any proceedings does not disqualify a regular member of the board. In addition, a Board member may not participate in a hearing or decision concerning a matter in which he/she has an interest. A member shall declare his/her known conflict of interest. The Board shall enter in its record the fact that its member has a disqualification. Members are expected to disclose any personal, non-financial interest in any matter before the Board, and may refuse to participate and vote on such matter. A member who has a conflict of interest shall leave the Board table. Such member may join the audience but may not give testimony on the matter before the Board. Nothing in this section shall prevent a member of the Board from presenting a petition on his/her own behalf, but members shall not appear before the Board on behalf of others.

c. Required - Except as provided in "b" above, a majority of the voting members of the board constitutes a quorum. An abstention or refusal to vote is, in effect, a declaration that they consent that the majority of the quorum may act for the body of which they are members.

d. Absentee - Absentee or proxy voting shall not be permitted. In the event that a member is absent for part of a public hearing, such member's eligibility to vote on the matter shall be at the discretion of the Chairman.

e. Electronic Participation- Authorized by Board Resolution NO. 2023-01, Any member may participate in a meeting by any electronic means of communication that allows all participating members of the governing body to simultaneously communicate with each other; and other than a meeting that is an executive session, allows the public to simultaneously attend and observe the meeting.

At least three of the members must be physically present at a meeting at which a member will participate by means of electronic communication. Not more than two of the members may participate by an electronic means of communication at that same meeting.

A member may not attend more than fifty percent (50%) of the meetings in a calendar year by an electronic means of communication, unless the member's electronic participation is due to:

- (1) military service;
- (2) illness or other medical condition;
- (3) death of a relative; or
- (4) an emergency involving actual or threatened injury to persons or property.

A member who participates by an electronic means of communication shall be considered present for purposes of establishing a quorum; and may participate in final action only if the member can be seen and heard.

All votes taken during a meeting at which at least one member participates by an electronic means of communication must be taken by roll call vote.

The minutes of a meeting at which any member participates by electronic means of communication must:

- (1) identify each member who:
 - (A) was physically present at the meeting;
 - (B) participated in the meeting by electronic means of communication; and
 - (C) was absent; and
- (2) identify the electronic means of communication by which:
 - (A) members participated in the meeting; and
 - (B) members of the public attended and observed the meeting if the meeting was not an executive session.

If a member participates by an electronic means it should be consider as attendance for compensation if compensation is given to others in attendance.

Section 3. Order of Business

The order of business shall be as listed below, except that said order of business may be changed by the Chairman upon the consenting vote of a majority of those members.

1. Call meeting to order
2. Roll call of members
3. Approval of Minutes
4. Swearing in
5. Public Hearings
6. Old Business
7. New Business
8. Reports and Recommendations
9. Adjournment

ARTICLE IV PUBLIC HEARING

Section 1. Procedure

a. Opening the hearing - The Chairman shall call the docket number of the item scheduled for public hearing and declare the public hearing open.

b. Order of testimony - The order of testimony shall be as follows, when petition is a plat or site reviewed by the Johnson County Surveyors Office:

1. Background and comments by the County Surveyor
2. Swearing in witnesses
3. Presentation of request by petitioner
4. Comments and questions by members of the audience
5. Rebuttals
6. Summations

Or, when petition is a plat or site reviewed by the Johnson County Planning Engineer:

1. Presentation of request by petitioner
2. Comments by the Johnson County Planning Engineer
3. Swearing in witnesses
4. Comments and questions by members of the audience
5. Rebuttals
6. Summations

c. Procedure for presentation and debate - Petitioner(s) and remonstrator(s), respectively, may be permitted a maximum of twenty (20) minutes for the presentation of evidence, statements, and argument at the public hearings of every case at the discretion of the Chairman:

1. Petitioner(s) and persons appearing in support of the case being heard by the Board may have fifteen (15) minutes collectively for the presentation of evidence, statements and argument in support of the matter being considered.

A reasonable addition time may then be allowed for cross-examination of petitioner's witness.

2. Remonstrator(s) and persons appearing in opposition to the case may then be given twenty (20) minutes collectively for the presentation of evidence, statements, and argument in opposition to the matter being considered.

A reasonable additional time may then be allowed for cross-examination and redirect examination of remonstrator's witnesses.

3. The petitioner(s) may then have five (5) minutes for rebuttal, which shall include only evidence, statements, and arguments in rebuttal of remonstrator's evidence and a brief closing statement.

The Chairman may, unless otherwise directed by a majority of the Board in session at the time, have authority to extend the total of twenty (20) minute periods specified above, where appropriate in the interest of affording to all interested parties a fair hearing.

d. Closing the hearing - After all public comments have been heard under the rules of this section, the Chairman shall declare the hearing closed and shall call for a motion. Additional public comment shall not be permitted after the close of the hearing. Any motion which has been made and seconded is open for discussion by the Board members, but such motion is closed to discussion by the public unless the Chairman specifically allows such discussion. The Chairman shall have the authority to limit such discussion by the public or the Board members.

e. Voting - Each motion on a matter requiring a public hearing shall be by voice vote of the members, in accordance with the provisions of Article III, Section 2 of these rules. The vote of each member shall become a part of the record on the petition, and the vote of each member shall be disclosed by any Board officer or the secretary for anyone requesting such information.

Section 2. Conduct

a. Representation - The petitioner may appear in person, by agent, or attorney, and present any supporting witnesses, evidence, statements, and arguments in favor of the request. Remonstrators and persons in favor of the request may appear in person, by agent, or by attorney, and present witnesses, evidence, statements, and arguments. Any person interested in any petition shall have the right but shall not be required to enter a written appearance in the hearing.

b. Board participation - The Board members shall be provided adequate opportunity to examine witnesses and question any evidence, statements and arguments in the interest of a fair hearing.

c. Identification - All persons wishing to be heard on any matter in a public hearing must stand before the Board and provide their names and addresses for the record.

d. Commentary addressed to Board - All commentary at a public hearing shall be addressed to the Board through its Chairman. Such commentary shall not be permitted between opposing parties without the consent of said officer.

e. Authority of Chairman - The Chairman shall have the authority to prohibit repetitious and irrelevant testimony and shall have authority to limit the length of testimony by each speaker deemed appropriate to a fair public hearing.

f. Orderly conduct - Every person appearing before the Board shall abide by the order and direction of the Chairman. Discourteous, disorderly, or contemptuous conduct shall not be tolerated, and the Chairman may take such action as is deemed necessary to prevent such conduct.

ARTICLE V DISPOSITION OF PETITIONS

Section 1. Motions

The final disposition of any petition duly filed and brought before the Board shall be in the form of a motion, properly adopted, specifically setting forth such disposition.

Section 2. Dismissal

a. Want of prosecution - The Board may dismiss a petition if the petitioner or authorized representative does not appear to present and speak in favor of such petition or if such petition has been improperly filed as determined by the Board.

b. Lack of jurisdiction - The Board shall dismiss a petition if it finds it has no jurisdiction over such matter.

c. If the petition is dismissed for want of prosecution, the petition shall not be again placed upon the docket for a hearing within a period of one hundred eighty (180) calendar days from the date of the originally scheduled hearing, except upon a motion duly adopted by a majority of the membership of the Board to permit such re-docketing. In the event a petition is dismissed for want of prosecution, a new filing fee shall be required unless a majority of the membership of the Board, by motion duly made and adopted, waives the imposition of an additional filing fee.

Section 3. Withdrawal

- a. Without prejudice - Any petition may be withdrawn without prejudice provided a written request for withdrawal signed by the petitioner or an authorized representative is received by the Board's secretary at least ten (10) calendar days before the scheduled hearing.
- b. With prejudice - Any request for withdrawal made less than ten (10) calendar days before the scheduled hearing may be granted or denied by the Board. Such request may be in writing or oral and must state the reasons for the request. If the Board votes to permit withdrawal, the petition shall not again be placed on the docket for a hearing within a period of one hundred eighty (180) calendar days from the date of the originally scheduled hearing, except upon a motion duly adopted by a majority of the membership of the Board to permit such re-docketing.
- c. Not permitted - No petition may be withdrawn after a motion has been made and seconded and a vote has been ordered by the Chairman.

Section 4. Continuance

- a. If requested by Petitioner, the request must be in writing and filed with the County Surveyor no later than five (5) business days immediately preceding the day of the scheduled hearing. One continuance will be allowed as a matter of right and without cause shown. The request shall include whether it is the first request for continuance. The Petitioner shall give notice to all interested parties required to be served with notice pursuant to Article VII herein, and to attorneys who have entered their appearance or are known to represent the petitioner(s) or remonstrator(s). If a continuance is granted, the petition shall be rescheduled for the next available meeting, unless otherwise requested. A request to reschedule to a date other than the next available meeting may only be granted by the Board.

If a continuance is granted, upon request of the Petitioner, re-notification will not be required in all cases. At the time a continuance is granted, the Board will determine whether or not notification of the new hearing date will be required. In most cases, if a hearing is rescheduled to the next regular meeting, re-notification will not be required. If a hearing is not ~~not~~ rescheduled at the time a continuance is granted, or if a hearing is rescheduled to a date other than the date of the next regular meeting, in most cases, renotification will be required. If re-notification is required, it shall be given pursuant to Article VII herein, and the Petitioner shall prepare and issue the notice and pay all cost associated therewith. Notice will not be required if a continuance is granted to surveyor, when more time is required for review.

The Petitioner must also give notice to all persons or entities receiving notice pursuant to Article VII of the filing of the request for continuance by mailing a copy of the request to each person or entity, first class, postage prepaid, at the time the request is filed with the Surveyor.

All other interested parties except the Petitioner may obtain one (1) continuance, in total, as a matter of right and without cause shown. Other interested parties except the Petitioner are encouraged to request a continuance in writing, five (5) business days immediately preceding the scheduled hearing. Other party will copy petitioner on request for continuance, and provide surveyors office with proof of notification.

Provided further, however, that any interested party other than Petitioner may request and obtain one (1) continuance as a matter of right and without cause shown by appearing at the scheduled hearing and making a request to the Board prior to the commencement of the hearing. Once the hearing has begun no continuance shall be granted to anyone except for good cause shown or upon motion of the Board. If a continuance is granted by the Board at the time of the hearing, at the request of an interested party other than the Petitioner, the Board will determine whether or not re-notification is required. If re-notification is required, it shall be given pursuant to Article VII herein, and the interested party requesting and receiving the continuance shall prepare and issue the notice and pay all costs associated therewith.

Second or subsequent continuances to either petitioner or interested parties shall not be allowed as a matter of right, but may be granted by the Board for good cause. The Board would then determine whether or not re-notification is required.

The Board reserves the right to continue the hearings at any time and from time to time. If a hearing is continued on motion of the Board, the Board shall determine if re-notification of the new hearing date is required and, if so, who must give the notice and pay costs associated therewith.

The term "business day" shall mean any day the office of the Johnson County Surveyor is actually open for business and in computing the period of "five (5) business days", neither the day of the filing of the written continuance request with the Surveyor or the day of the scheduled hearing will be included.

Section 5. Approval

a. Final Subdivisions and planned unit developments - The Board has the authority to approve the drainage plans for subdivisions of land and planned unit developments under the terms of The Johnson County Comprehensive Stormwater Management Ordinance, the Subdivision Control Ordinance - section 6-102-5 Drainage, or under any other duties or responsibilities that the Board may adopt.

1. Preliminary approval- A motion to approve a petition may be conditional upon a petitioner's compliance with a requirement or requirements imposed by the Board. Such condition(s) of approval shall be specifically stated and recited to the petitioner. The Board may impose a time limit upon the fulfillment of any such requirement(s). The petitioner shall be required to notify the Drainage Board's secretary of the fulfillment of such requirements by filing an affidavit of compliance with the Board. If the time for fulfillment of the condition(s) is stated in the Board's decision, such affidavit shall be filed within thirty (30) calendar days after the time allowed for fulfillment. In the event any condition of the decision has not been fulfilled or the time for compliance has expired, the decision shall be revoked and rescinded.

2. Final approval- Petitioners may be required to appear before the Board for a subsequent hearing on final approval. Petitioners shall not seek a hearing date for final approval until such is recommended by the staff.

3. Time Limitations Governing Preliminary Approval and Extensions of Time- If the Board has not imposed time limits upon the fulfillment of any requirements imposed pursuant to Sub-Sub Section 1 above, preliminary approval shall automatically expire two (2) years from the date of the approval being granted. If the Board has imposed time limits, then such time limits shall control. If an application for final approval is not filed within the time limits imposed pursuant to Sub-Sub Section 1 above or, in any event, within two (2) years from the date that preliminary approval was granted, such preliminary approval will be deemed to be null and void and of no force or effect. The Board, for good cause shown, may allow an extension of time for any time limit imposed herein. Applicants seeking an extension of time shall file their requests no later than thirty (30) days prior to the date of expiration of preliminary approval. Failure to file for an extension of time at least thirty (30) days prior to the expiration of preliminary approval will result in an automatic denial of the request for

extension of time. If a request for extension of time is timely filed, the Petitioner shall appear before the Board at a date and time fixed by the Board to explain why final approval could not be sought within the time limits imposed. All notices required to be given for preliminary and final approval shall be given in the event a Petitioner seeks an extension of time. The Board shall, in its sole discretion, determine whether or not an extension of time shall be allowed.

Section 6. Disapproval

If the Board finds that a petition does not meet the criteria established by ordinance(s) or state statute(s) for approval, it shall deny the request. No petition which has been denied pursuant to this Section shall again be placed on the docket for hearing for a period of one hundred eighty (180) calendar days from the date of such denial, except upon a motion duly adopted by a majority of the membership of the Board to permit such re-docketing. A new filing fee shall be required unless a majority of the Board, by motion duly made and adopted, waives the imposition of an additional filing fee.

ARTICLE VI FILING PROCEDURES

Section 1. Application

Each petition to the Board shall be filed in the office of the Surveyor and be on application forms approved by the Board. They shall be accompanied by such information and exhibits as specified on such forms and/or required by applicable ordinances. Any communication purporting to be a petition not on the prescribed forms or not containing the information required shall be considered incomplete and shall not be docketed. Any application which is incomplete at the time of the filing deadline shall not be docketed.

Section 2. Filing Deadlines

The secretary shall prepare, no later than the regular December Meeting of each year, a schedule of the filing deadlines for the ensuing year. Such schedule shall provide for adequate time for the surveyor, and staff to review the proposal and offer technical advice to the Board and shall provide adequate time of issuance of required notices. Any application which is incomplete at the time of the filing deadline shall not be docketed.

Section 3. Eligible Applicants

The owner(s) of the property included in any petition before the Board must consent to the filing of the application. Such consent may be evidenced by the owner's notarized signature on said application or by signature of a person having power of attorney authorizing such signature. In the case of property which is being purchased by a land contract, the consent of both the contract purchasers and the contract sellers or their duly authorized agents shall be required.

ARTICLE VII NOTICE REQUIREMENTS

Section 1. Contents

Any notice of public hearing by federal, state, or local law shall contain as a minimum the following necessary information:

- a. Docket number, obtained from board secretary
- b. Subject and the substance of the matter to be heard.

Section 1. Contents Cont.

- c. General location by mailing address, township, and recorded legal description of the property.
- d. Name of the person or agency initiating the matter to be heard.
- e. Time, date, and place of the hearing.
- f. Statement that the petition may be examined at the office of the County Surveyor.
- g. Statement that interested parties may offer an oral opinion at the hearing or may file written comments concerning the matter to be heard prior to or at the hearing.
- h. Any other information which may be required by law to be contained in such notice.

Section 2. Publications

Notice by publication containing all necessary information shall be given by the petitioner(s) in a newspaper of general circulation in Johnson County, at least ten (10) calendar days before the hearing, and proof of publication shall be made by an affidavit of the publisher attached to a copy of the notice taken from the newspaper in which it was taken and filed with the Board Secretary. Such affidavit shall specify the county, the time of publication, and the paper in which the notice was published. The petitioner(s) shall assume the cost of said publication. Proof of such publication shall be provided to secretary by petitioner and kept in the appropriate file.

Section 3. Mailed Notice

a. Method of Notice - Notice shall be given to owners of all property within a distance of six hundred (600) feet or two (2) property owners, in all directions, from the boundaries of the affected property, whichever is greater. Notification by certificate of mail shall be sent not less than ten (10) calendar days prior to the hearing, with said notice containing the following necessary information.

Section 3. Mailed Notice, Cont.

- a. Docket number, obtained from board secretary
- b. Subject and the substance of the matter to be heard.
- c. General location by mailing address, township, and recorded legal description of the property.
- d. Name of the person or agency initiating the matter to be heard.
- e. Time, date, and place of the hearing.
- f. Statement that the petition may be examined at the office of the County Surveyor.
- g. Statement that interested parties may offer an oral opinion at the hearing or may file written comments concerning the matter to be heard prior to or at the hearing.
- h. Any other information which may be required by law to be contained in such notice.

In the alternative, the petitioner(s) may present a list of all such owners, signed by such owners and acknowledging notice of the petition and hearing, said list having affidavit affixed attesting to the veracity of the list, with the petitioner(s) signature being notarized.

b. Determination of owners - The names and addresses of the property owners to be notified are to be determined from the records of the Auditor of Johnson County (Mapping Department). They shall be deemed to be the true names and addresses of the persons entitled to notice. For the purpose of determining adjoining parcels of land, the land described in said petition shall be deemed to include any adjoining land owned by the applicant, provided, however, such

ownership shall not be deemed to include the entire length of the right-of-way of a street, railway or parcel involved. Land separated from petitioned property by streets, railways, easements and the like shall be deemed to be land adjoining the petitioned land.

Section 4. Evidence of Notice

Certificate of mail receipts, notarized affidavits listing the names and addresses of the property owners, and proof of service of said notice shall be considered evidence that notice has been given. Personal appearance at the hearing shall constitute evidence of notice.

Section 5. Multiple Approvals and Multiple Notices

All provisions for notifications and publications shall apply to petitions that require multiple approvals. (For example, preliminary approval and final approval that are required for major plats.)

ARTICLE VIII COMMITTEES

Section 1. Authority

The Chairman is hereby authorized to appoint permanent and temporary committees to facilitate the work of or advise the Board. Such committees may be comprised of Board members and other interested parties. A chairman shall be appointed for each committee, and reports on their assignments shall be made a part of the record. The Chairman shall be an ex-officio member of any committee.

ARTICLE IX BOARD RECORDS

Section 1. Responsibility It shall be the duty of the Recording Secretary of the Board to maintain all Board files and records, including the official minutes of all meetings.

Section 2. Minutes

The Recording Secretary shall prepare an accurate record of all hearings and official actions of the Board, and the written minutes representing such record shall be made available within a reasonable time after approval of the Board. Approved minutes shall be made available for inspection by the public in the Office of the County Surveyor.

Section 3. Tape Recordings

The Recording Secretary may make taped copies or other mechanical recordings of the Board's proceeding. Such recording products shall remain on file in the Surveyor's office for a period not less than one (1) year from the date of the hearing or determination, whichever is later. Such recordings shall not be removed from the Surveyor's office other than by order of a court of competent jurisdiction. Interested parties may listen to such recordings, under the supervision of the Surveyor's staff. The Recording Secretary may utilize other recordings provided by the county commissioners, or county department personnel working under the auspices of the county commissioners. Access to those recordings would be made through the county commissioner's office.

Section 4. Board Case Files

A file shall be maintained in the Surveyor's office for each item placed on the docket of the Board. Such files shall contain, as a minimum, the application form and supporting materials and any exhibits pertinent to the decision, conditions, or safeguards or other material related to the binding effects of the Boards actions.

Section 5. Public Records

The records and files for the Board shall be made available to the public under the provisions of IC 5-14-3, the Indiana Access to Public Records Law, and any amendments thereto. The County Surveyor is hereby designated as the officer responsible for determining which documents of the Board are public records. Any person may file a written objection to a decision of the Surveyor under this section. Upon receipt of such objection, the Surveyor shall consult the Board Chairman and the Board attorney who shall decide whether a requested document is public record.

The county surveys office will maintain those records in accordance with the laws, rules, and procedures as outlined in The Surveyors Retention Schedule (SU 23. 01-06) of The Indiana Archives & Records Administration (IARA).

ARTICLE X FEES

Section 1. Schedule of Fees

The Board may establish a uniform fee schedule of fees to defray the administrative costs connected with processing, reviewing, and hearing petitions. Such fees shall not exceed the

actual costs of providing such services. Fees established can include fees for copying documents under the provisions of IC 5-14-3-8(d).

Section 2. Payment Required

In no case shall the Board take action on any petition for which applicable fees have not been paid in full. No part of any fee paid pursuant to this section shall be returnable to the petitioner.

Section 3. Waivers

Nothing herein shall be construed to require a fee for actions initiated in the public interest of the Board.

ARTICLE XI AMENDMENTS AND SUSPENSION

Section 1. Amendments

Amendments to the Rules and Procedure may be made by the Board at any regular or special meeting upon the affirmative vote of a majority of the membership of the Board, provided, however, that the proposed amendment shall have been presented in writing at a previous regular meeting of the Board.

ARTICLE XII SEPARABILITY

If any section, clause, provision, or portion of these rules shall be held invalid or unconstitutional by a court of competent jurisdiction, such decision shall not affect the validity or constitutionality of any other section, clause, provision, or portion of these rules.

ARTICLE XIII CERTIFICATE OF ADOPTION These rules are hereby adopted by the affirmative vote of the Johnson County Drainage Board this 1st day of October, 1996; amended September 2, 1997; amended July 21, 1999; amended August 15, 2000; amended August 20, 2002, amended October 21, 2003.

RULES OF PROCEDURE ADOPTED: OCTOBER 1, 1996 AMENDED: September 2, 1997
AMENDED: July 21, 1999 AMENDED: August 15, 2000 AMENDED: August 20, 2002
AMENDED: October 21, 2003 AMENDED: December 20, 2006, AMENDED: January 3, 2023

1. Fees \$375.00* *(Make checks payable to Johnson County Drainage Board)*

Project site may require more than one application, or permission, as well as more than one fee. Applications, and petitions may run consecutively, at the discretion of the county surveyor.

* Note, Fees include up to 1 hour of review, all other review time is subject to a \$200.00 hourly charge. Fee also includes one legal drain sign.

Additional Review Fees are charged on an hourly basis, applicants will be billed, and invoices are due within 30 days of invoice.

1. Bond (Minimum \$5,000.00 Surety or Cash Bond)

A bond for performance or site improvement is required. The bond may be a cash bond (Check payable to Johnson County Surveyor), or a surety bond. Bond amount is based on petitioners estimated cost of all proposed work within to be performed within the drainage easement. Surety bonds are subject to legal review. After inspection (confirmation of proper installation), the surveyors office will release the obligation, and payment will be returned to applicant.

Drainage Board Attorney
(Surety Bond Review)

Roger Young
Young & Young
40 West Court Street
Franklin, Indiana 46131
Ph. 317-736-7117
Email: youngandyounglaw@gmail.com

Surveyor’s Office
(Cash Bond)

Johnson County Surveyors Office
Johnson County Drainage Board
86 West Court Street
Franklin, Indiana 46131
Phone: 317-346-4343
Email: gcantwell@co.johnson.in.us

Bond Amount

Petitioners estimated cost of all proposed work within to be performed within the drainage easement.

1. Deadlines

Filing deadline is approximately 30 days prior to drainage board meeting. Drainage Board Secretary prepares an annual schedule of approved filing deadlines, and drainage board meeting dates, said schedule is available after the December drainage board meeting.

If filing deadline falls on a day that the county offices are closed the date shall be forwarded to the next business day. All applications / petitions are due, in full, and payable, during office receiving hours: Monday- Friday, 8am-12 Noon, & 1pm-4pm, including those mailed or delivered.

County surveyor reserves the right to move applications and petitions to the next available meeting night because additional review time is needed, hearing date is full, or other scheduling conflicts necessitate.

Notice of Hearing

No notice of hearing is necessary for this application, except when outlet is located on an adjacent, parcel that is not owned by applicant, or petitioner. Applicant, or petitioner must notify affected property owner (Article VII, Notice Requirements, Sec. 3 & 4).

A detailed plan of work (installation) is to be filed with the surveyor, including but not necessarily limited to, the physical work area, point of entry, work time frame, restoration, and letter of agreement between applicant and property owner.

2. Application

Each petition to the Board shall be filed in the office of the Surveyor and be on application forms approved by the Board. They shall be accompanied by such information and exhibits as specified on such forms and/or required by applicable ordinances. Any communication purporting to be a petition not on the prescribed forms or not containing the information required shall be considered incomplete and shall not be docketed. Any application which is incomplete at the time of the filing deadline shall not be docketed.

APPLICATION FOR: Outlet larger than 10 Inches

DATE FILED: _____ REQUESTED HEARING DATE: _____

PETITIONER: _____

ADDRESS: _____

PROPERTY DESCRIPTION: _____

LEGAL DRAIN _____

Johnson Co. Parcel No. _____

Brief explanation of encroachment: _____

Contractor & Contact _____

DRAINAGE BOARD USE ONLY DOCKET NUMBER _____

Fee Paid _____ Bond Type & Amount _____

Approved _____ Continued _____ Denied _____

Conditions: _____

3. Support Documents, Surveys, Plats, Plans, and Drainage Reports

Each application / petition to the drainage board shall be filed, in person, in the office of the county surveyor, at the appropriate place and time, and be on supplied forms approved by the county surveyor. They shall be accompanied by such information, **surveys**, reports, calculations, **photographs**, and exhibits as forms specify, or required by ordinances, and procedures. Any communication, or informal requests purporting to be a petition not on the prescribed forms or not containing adequate information required, shall be considered incomplete and may not be docketed, at the discretion of the county surveyor, or board. Any application which is incomplete at the time of filing deadline shall not be docketed. All applications / petitions are fluid, additional time maybe required for review, or the types of applications my limit the meeting agenda.

Support documentation shall include, but not be limited to:

1. Seven (7) Paper Copies*, of which five of the plan sets can be reduced (11x17).
2. Two copies of Subdivision Plat & Deed of Record
3. Photographs
4. One (1) PDF, on portable drive, or emailed to: gcantwell@co.johnson.in.us

* Paper Copies refer to Sketch Plan, Survey, Plat, Construction Plans, or other large format support documentation.

Office Location:

Johnson County Surveyors Office
Johnson County Drainage Board
86 West Court Street
Franklin, Indiana 46131
Phone: 317-346-4343
Email: gcantwell@co.johnson.in.us

Office Receiving Hours: Monday- Friday, 8am-12 Noon, & 1pm- 4pm

No permanent structures, trees, shrubs or other woody vegetation shall be placed within the legal drain easement without the written consent of the Johnson County Drainage Board. Any structure or vegetation or crops located within the legal drain easement, regardless of whether or not written consent was given, shall be removed by the owner, at the owner's expense, if so requested by the Johnson County Drainage Board or the Johnson County Surveyor. Any damage caused anything planted, erected, place, maintained, or existing within the easement shall be without liability to the Surveyor, the Drainage Board, or their representatives. Authority: 1.C.36-9-27-33

**RULES OF PROCEDURE
JOHNSON COUNTY DRAINAGE BOARD
ARTICLE I AUTHORITY, DUTIES**

Section 1. Authority

The Johnson County Drainage Board (hereinafter called "Board") exists under authority of Indiana Code 36-9-27-4, and all acts supplemental and amendatory thereto.

Section 2. Duties

The Duties of the Johnson County Drain Board shall be those set forth in IC 36-9-27-1, et seq, "DRAINAGE LAWS" and such other responsibilities as may be adopted by the Board.

Section 3. Membership

The Board shall consist of three or five members in accordance with IC 36-9-27-5.

Section 4. Meetings

All meetings of the Board shall be conducted in accordance with IC-36-9-27-7, The Indiana Open Door Law, and any amendments thereto. On-site inspections of property involved in petitions before the Board shall not be considered meetings.

a. Regular meetings - The Board shall hold a regular meeting on the first and third Tuesday of each month. Whenever the regular meeting date falls on an official holiday or precedes Election Day, another date shall be selected. A schedule of all regular meetings shall be published each year. All regular meetings shall be held in the public hearing room of the Johnson County Annex at the times designated on the schedule of meetings, unless otherwise designated by the Board.

b. Special Meetings - In accordance with the provision of IC 36-9-27-7(d), special meetings of the Board may be called at any time by the Chairman, any two (2) members, or the county surveyor, by mailing a written notice setting forth the time, date, and place of the meeting to each member not less than five (5) days before the date of the meeting. A member may waive the mailing of notice of a special meeting by filing a written waiver with the secretary or by his presence at the meeting.

c. Cancellation - Whenever there is a lack of business for Board consideration, the Chairman may dispense with a regular meeting. In such case, the secretary of the Board shall give written notice of all members, and the news media shall be notified of such a cancellation. Whenever it is determined that a quorum is not available for a regular or special meeting, the Chairman of the Board shall dispense with such meeting, and all business scheduled for such meeting will be automatically continued to the next regular or special meeting. In such cases, the secretary of the Board shall give written or oral notice to the Board members, those having business before the Board, and to the news media. The Chairman of the Board also may dispense with a scheduled regular or special meeting in the event of a natural disaster, snow emergency, or similar causes.

c. continued

In such cases, the secretary of the Board shall give written or oral notice to the Board members and those having business before the Board if possible, and the secretary notify the news media of the cancellation. In the event of cancellation for any reason, the Chairman may require re-notification to interested parties, with such notice to be paid for by the petitioner or by the Board, as the Chairman deems appropriate.

ARTICLE II OFFICERS AND RECORDING SECRETARY

Section 1. Board Officers

In accordance with IC 36-9-27-7(a), at its first regular meeting of each year, the Board shall elect from its members a Chairman, Vice Chairman, and Secretary. The Board shall appoint a recording secretary, and an attorney.

Section 2. Duties of Board Officers

a. Chairman - The Chairman shall preside over Board meetings and on behalf of the Board shall exercise general supervision over the affairs of the Board, the appointment of committees and representatives, and determination of points of order and procedure, and the signing of all official documents.

b. Vice Chairman - The Vice Chairman shall have authority to act as Chairman of the Board during the absence or disability of the Chairman.

c. Secretary - The Secretary shall certify all official acts of the Board and the Vice Chairman, the Secretary shall preside, provided, however, the first and only item of business to be presented by such presiding officers shall be the election of a Chairman pro tempore. In the event of the absence or disability of the Secretary, the Chairman of the Board shall select a Secretary pro tempore.

d. Directives - Any policies or assignments to the secretary not covered by these regulations shall be by resolution of the Board.

ARTICLE III CONDUCT OF MEETINGS

Section 1. Quorum

A majority of the voting members of the board constitutes a quorum, and the concurrence of a majority of the voting members present at a meeting is necessary to authorize any action under this chapter.

Section 2. Voting

a. Majority - No action of the Board is official unless it is authorized at a regular or special meeting by a majority of the voting members present at the meeting.

b. Conflict of interest - In accordance with IC 36-9-27-12, whenever it appears, in any proceeding for the construction, reconstruction, or maintenance of a regulated drain, that a member of the board has an interest in the proceedings because of his ownership of real property affected by the drain, that member shall immediately disqualify himself from serving on the board in those proceedings. However, the fact that county highways will be affected by any proceedings does not disqualify a regular member of the board. In addition, a Board member may not participate in a hearing or decision concerning a matter in which he/she has an interest. A member shall declare his/her known conflict of interest. The Board shall enter in its record the fact that its member has a disqualification. Members are expected to disclose any personal, non-financial interest in any matter before the Board, and may refuse to participate and vote on such matter. A member who has a conflict of interest shall leave the Board table. Such member may join the audience but may not give testimony on the matter before the Board. Nothing in this section shall prevent a member of the Board from presenting a petition on his/her own behalf, but members shall not appear before the Board on behalf of others.

c. Required - Except as provided in "b" above, a majority of the voting members of the board constitutes a quorum. An abstention or refusal to vote is, in effect, a declaration that they consent that the majority of the quorum may act for the body of which they are members.

d. Absentee - Absentee or proxy voting shall not be permitted. Members must be present for the public hearing in order to be eligible to vote on any matter. In the event that a member is absent for part of a public hearing, such member's eligibility to vote on the matter shall be at the discretion of the Chairman.

Section 3. Order of Business

The order of business shall be as listed below, except that said order of business may be changed by the Chairman upon the consenting vote of a majority of those members.

1. Call meeting to order 2. Roll call of members 3. Approval of Minutes 4. Public Hearings 5. Old Business 6. New Business 7. Reports and Recommendations 8. Adjournment

ARTICLE IV PUBLIC HEARING

Section 1. Procedure

a. Opening the hearing - The Chairman shall call the docket number of the item scheduled for public hearing and declare the public hearing open.

b. Order of testimony - The order of testimony shall be as follows:

1. Background and comments by the County Surveyor 2. Swearing in witnesses 3. Presentation of request by petitioner 4. Comments and questions by members of the audience 5. Rebuttals 6. Summations

c. Procedure for presentation and debate - Petitioner(s) and remonstrator(s), respectively, may be permitted a maximum of twenty (20) minutes for the presentation of evidence, statements, and argument at the public hearings of every case at the discretion of the Chairman:

1. Petitioner(s) and persons appearing in support of the case being heard by the Board may have fifteen (15) minutes for the presentation of evidence, statements and argument in support of the matter being considered.

A reasonable addition time may then be allowed for cross-examination of petitioner's witness.

2. Remonstrator(s) and persons appearing in opposition to the case may then be given twenty (20) minutes for the presentation of evidence, statements, and argument in opposition to the matter being considered.

A reasonable additional time may then be allowed for cross-examination and redirect examination of remonstrator's witnesses.

3. The petitioner(s) may then have five (5) minutes for rebuttal, which shall include only evidence, statements, and arguments in rebuttal of remonstrator's evidence and a brief closing statement.

The Chairman may, unless otherwise directed by a majority of the Board in session at the time, have authority to extend the total of twenty (20) minute periods specified above, where appropriate in the interest of affording to all interested parties a fair hearing.

d. Closing the hearing - After all public comments have been heard under the rules of this section, the Chairman shall declare the hearing closed and shall call for a motion. Additional public comment shall not be permitted after the close of the hearing. Any motion which has been made and seconded is open for discussion by the Board members, but such motion is closed to discussion by the public unless the Chairman specifically allows such discussion. The Chairman shall have the authority to limit such discussion by the public or the Board members.

e. Voting - Each motion on a matter requiring a public hearing shall be by voice vote of the members, in accordance with the provisions of Article III, Section 2 of these rules. The vote of each member shall become a part of the record on the petition, and the vote of each member shall be disclosed by any Board officer or the secretary for anyone requesting such information.

Section 2. Conduct

- a. Representation - The petitioner may appear in person, by agent, or attorney, and present any supporting witnesses, evidence, statements, and arguments in favor of the request. Remonstrators and persons in favor of the request may appear in person, by agent, or by attorney, and present witnesses, evidence, statements, and arguments. Any person interested in any petition shall have the right but shall not be required to enter a written appearance in the hearing.
- b. Board participation - The Board members shall be provided adequate opportunity to examine witnesses and question any evidence, statements and arguments in the interest of a fair hearing.
- c. Identification - All persons wishing to be heard on any matter in a public hearing must stand before the Board and provide their names and addresses for the record.
- d. Commentary addressed to Board - All commentary at a public hearing shall be addressed to the Board through its Chairman. Such commentary shall not be permitted between opposing parties without the consent of said officer.
- e. Authority of Chairman - The Chairman shall have the authority to prohibit repetitious and irrelevant testimony and shall have authority to limit the length of testimony by each speaker deemed appropriate to a fair public hearing.
- f. Orderly conduct - Every person appearing before the Board shall abide by the order and direction of the Chairman. Discourteous, disorderly, or contemptuous conduct shall not be tolerated, and the Chairman may take such action as is deemed necessary to prevent such conduct.

ARTICLE V DISPOSITION OF PETITIONS

Section 1. Motions

The final disposition of any petition duly filed and brought before the Board shall be in the form of a motion, properly adopted, specifically setting forth such disposition.

Section 2. Dismissal

- a. Want of prosecution - The Board may dismiss a petition if the petitioner or authorized representative does not appear to present and speak in favor of such petition or if such petition has been improperly filed as determined by the Board.
- b. Lack of jurisdiction - The Board shall dismiss a petition if it finds it has no jurisdiction over such matter.
- c. If the petition is dismissed for want of prosecution, the petition shall not be again placed upon the docket for a hearing within a period of one hundred eighty (180) calendar days from the date of the originally scheduled hearing, except upon a motion duly adopted by a majority of the membership of the Board to permit such re-docketing. In the event a petition is dismissed for want of prosecution, a new filing fee shall be required unless a majority of the membership of the Board, by motion duly made and adopted, waives the imposition of an additional filing fee.

Section 3. Withdrawal

- a. Without prejudice - Any petition may be withdrawn without prejudice provided a written request for withdrawal signed by the petitioner or an authorized representative is received by the Board's secretary at least fourteen (14) calendar days before the scheduled hearing.

b. With prejudice - Any request for withdrawal made less than fourteen (14) calendar days before the scheduled hearing may be granted or denied by the Board. Such request may be in writing or oral and must state the reasons for the request. If the Board votes to permit withdrawal, the petition shall not again be placed on the docket for a hearing within a period of one hundred eighty (180) calendar days from the date of the originally scheduled hearing, except upon a motion duly adopted by a majority of the membership of the Board to permit such re-docketing.

c. Not permitted - No petition may be withdrawn after a motion has been made and seconded and a vote has been ordered by the Chairman.

Section 4. Continuance

a. If requested by Petitioner, the request must be in writing and filed with the County Surveyor no later than five (5) business days immediately preceding the day of the scheduled hearing. One continuance will be allowed as a matter of right and without cause shown. The request shall include whether it is the first request for continuance. The Petitioner shall give notice to all interested parties required to be served with notice pursuant to Article VII herein, and to attorneys who have entered their appearance or are known to represent the petitioner(s) or remonstrator(s). If a continuance is granted, the petition shall be rescheduled for the next available meeting, unless otherwise requested. A request to reschedule to a date other than the next available meeting may only be granted by the Board.

If a continuance is granted, upon request of the Petitioner, re-notification will not be required in all cases. At the time a continuance is granted, the Board will determine whether or not notification of the new hearing date will be required. In most cases, if a hearing is rescheduled to the next regular meeting, re-notification will not be required. If a hearing is not rescheduled at the time a continuance is granted, or if a hearing is rescheduled to a date other than the date of the next regular meeting, in most cases, renotification will be required. If re-notification is required, it shall be given pursuant to Article VII herein, and the Petitioner shall prepare and issue the notice and pay all cost associated therewith.

The Petitioner must also give notice to all persons or entities receiving notice pursuant to Article VII of the filing of the request for continuance by mailing a copy of the request to each person or entity, first class, postage prepaid, at the time the request is filed with the Surveyor.

The Petitioner must file with the Surveyor at the time the request for continuance is filed a "Certificate Of Mailing Notices" in the following Form:

"I, _____, affirm under penalties of perjury that I mailed or personally caused to be mailed to the individuals or entities shown on the attached Exhibit a copy of the "Request For Continuance", first class, postage prepaid, on this _____ day of _____, _____.
Signature: _____ Printed: _____

All other interested parties except the Petitioner may obtain one (1) continuance, in total, as a matter of right and without cause shown. Other interested parties except the Petitioner are encouraged to request a continuance five (5) business days immediately preceding the scheduled hearing. If a request is made at least five (5) business days immediately preceding the scheduled hearing, then the notice requirements imposed upon the petitioner shall be complied with by the requesting party.

Provided further, however, that any interested party other than Petitioner may request and obtain one (1) continuance as a matter of right and without cause shown by appearing at the scheduled hearing and making a request to the Board prior to the commencement of the hearing. Once the hearing has begun no continuance shall be granted to anyone except for good cause shown or upon motion of the Board. If a continuance is granted by the Board at the time of the hearing, at the request of an interested party other than the Petitioner, the Board will determine whether or not re-notification is required. If re-notification is required, it shall be given pursuant to Article VII herein, and the interested party requesting and receiving the continuance shall prepare and issue the notice and pay all costs associated therewith.

Second or subsequent continuances to either petitioner or interested parties shall not be allowed as a matter of right, but may be granted by the Board for good cause.

The Board reserves the right to continue the hearings at any time and from time to time . If a hearing is continued on motion of the Board, the Board shall determine if re-notification of the new hearing date is required and, if so, who must give the notice and pay costs associated therewith.

The term "business day" shall mean any day the office of the Johnson County Surveyor is actually open for business and in computing the period of "five (5) business days", neither the day of the filing of the written continuance request with the Surveyor or the day of the scheduled hearing will be included.

Section 5. Approval

a. Subdivisions and final planned unit developments - The Board has the authority to approve the drainage plans for subdivisions of land and planned unit developments under the terms of the Subdivision Control Ordinance, section 6-102-5 DRAINAGE and any other duties or responsibilities that the Board may adopt.

1. Preliminary approval- A motion to approve a petition may be conditional upon a petitioner's compliance with a requirement or requirements imposed by the Board. Such condition(s) of approval shall be specifically stated and recited to the petitioner. The Board may impose a time limit upon the fulfillment of any such requirement(s). The petitioner shall be required to notify the Board's secretary of the fulfillment of such requirements by filing an affidavit of compliance with the Board. If the time for fulfillment of the condition(s) is stated in the Board's decision, such affidavit shall be filed within thirty (30) calendar days after the time allowed for fulfillment. In the event any condition of the decision has not been fulfilled or the time for compliance has expired, the decision shall be revoked and rescinded.

2. Final approval- Petitioners may be required to appear before the Board for a subsequent hearing on final approval. Petitioners shall not seek a hearing date for final approval until such is recommended by the staff.

3. Time Limitations Governing Preliminary Approval and Extensions of Time- If the Board has not imposed time limits upon the fulfillment of any requirements imposed pursuant to Sub-Sub Section 1 above, preliminary approval shall automatically expire two (2) years from the date of the approval being granted. If the Board has imposed time limits, then such time limits shall control. If an application for final approval is not filed within the time limits imposed pursuant to Sub-Sub Section 1 above or, in any event, within two (2) years from the date that preliminary approval was granted, such preliminary approval will be deemed to be null and void and of no force or effect. The Board, for good cause shown, may allow an extension of time for any time limit imposed herein. Applicants seeking an extension of time shall file their requests no later than thirty (30) days prior to the date of expiration of preliminary approval. Failure to file for an extension of time at least thirty (30) days prior to the expiration of preliminary approval will result in an automatic denial of the request for extension of time. If a request for extension of time is timely filed, the Petitioner shall appear before the Board at a date and time fixed by the Board to explain why final approval could not be sought within the time limits imposed. All notices required to be given for preliminary and final approval shall be given in the event a Petitioner seeks an extension of time. The Board shall, in its sole discretion, determine whether or not an extension of time shall be allowed.

Section 6. Disapproval

If the Board finds that a petition does not meet the criteria established by ordinance(s) or state statute(s) for approval, it shall deny the request. No petition which has been denied pursuant to this Section shall again be placed on the docket for hearing for a period of one hundred eighty (180) calendar days from the date of such denial, except upon a motion duly adopted by a majority of the membership of the Board to permit such re-docketing. A new filing fee shall be required unless a majority of the Board , by motion duly made and adopted, waives the imposition of an additional filing fee.

ARTICLE VI FILING PROCEDURES

Section 1. Application

Each petition to the Board shall be filed in the office of the Surveyor and be on application forms approved by the Board. They shall be accompanied by such information and exhibits as specified on such forms and/or required by applicable ordinances. Any communication purporting to be a petition not on the prescribed forms or not containing the information required shall be considered incomplete and shall not be docketed. Any application which is incomplete at the time of the filing deadline shall not be docketed.

Section 2. Filing Deadlines

The secretary shall prepare, no later than the fifteenth (15) day of December of each year, a schedule of the filing deadlines for the ensuing year. Such schedule shall provide for adequate time for the surveyor to review the proposal and offer technical advice to the Board and shall provide adequate time of issuance of required notices. Any application which is incomplete at the time of the filling deadline shall not be docketed.

Section 3. Eligible Applicants

The owner(s) of the property included in any petition before the Board must consent to the filling of the application. Such consent may be evidenced by the owner's notarized signature on said application or by signature of a person having power of attorney authorizing such signature. In the case of property which is being purchased by a land contract, the consent of both the contract purchasers and the contract sellers or their duly authorized agents shall be required.

ARTICLE VII NOTICE REQUIREMENTS

Section 1. Contents

Any notice of public hearing by federal, state, or local law shall contain as a minimum the following information:

- a. Docket number and the substance of the matter to be heard.
- b. General location by mailing address, township, and recorded legal description of the property.
- c. Name of the person or agency initiating the matter to be heard.
- d. Time, date, and place of the hearing.
- e. Statement that the petition may be examined at the office of the County Surveyor.
- f. Statement that interested parties may offer an oral opinion at the hearing or may file written comments concerning the matter to be heard prior to or at the hearing.
- g. Any other information which may be required by law to be contained in such notice.

Section 2. Publications

Notice by publication containing all necessary information shall be given by the petitioner(s) in a newspaper of general circulation in Johnson County, at least ten (10) calendar days before the hearing, and proof of publication shall be made by an affidavit of the publisher attached to a copy of the notice taken from the newspaper in which it was taken and filed with the Board. Such affidavit shall specify the county, the time of publication, and the paper in which the notice was published. The petitioner(s) shall assume the cost of said publication. Proof of such publication shall be provided to secretary by petitioner and kept in the appropriate file.

Section 3. Mailed Notice

a. Method of Notice - Notice shall be given to owners of all property within a distance of six hundred (600) feet or two (2) property owners, whichever is greater, from the boundaries of the affected property. Notification by certified mail shall be sent not less than ten (10) calendar days prior to the hearing, with said notice containing the following information.

1. Docket number and the substance of the matter to be heard.
2. General location by mailing address, township, and recorded legal description of the property.
3. Name of the person or agency initiating the matter to be heard.
4. Time, date, and place of the hearing.
5. Statement that the petition may be examined at the office of the County Surveyor.
6. Statement that interested parties may offer an oral opinion at the hearing or may file written comments concerning the matter to be heard prior to or at the hearing.
7. Any other information which may be required by law to be contained in such notice.

In the alternative, the petitioner(s) may present a list of all such owners, signed by such owners and acknowledging notice of the petition and hearing, said list having affidavit affixed attesting to the veracity of the list, with the petitioner(s) signature being notarized.

b. Determination of owners - The names and addresses of the property owners to be notified are to be determined from the records of the Auditor of Johnson County. They shall be deemed to be the true names and addresses of the persons entitled to notice. For the purpose of determining adjoining parcels of land, the land described in said petition shall be deemed to include any adjoining land owned by the applicant, provided, however, such ownership shall not be deemed to include the entire length of the right-of-way of a street, railway or parcel involved. Land separated from petitioned property by streets, railways, easements and the like shall be deemed to be land adjoining the petitioned land.

Section 4. Evidence of Notice

Certified mail receipts and notarized affidavits listing the names and addresses of the property owners and proof of service of said notice shall be considered evidence that notice has been given. Personal appearance at the hearing shall constitute evidence of notice.

Section 5. Multiple Approvals and Multiple Notices

All provisions for notifications and publications shall apply to petitions that require multiple approvals. (For example, preliminary approval and final approval that are required for major plats.)

ARTICLE VIII COMMITTEES

Section 1. Authority

The Chairman is hereby authorized to appoint permanent and temporary committees to facilitate the work of or advise the Board. Such committees may be comprised of Board members and other interested parties. A chairman shall be appointed for each committee, and reports on their assignments shall be made a part of the record. The Chairman shall be an ex- officio member of any committee.

ARTICLE IX BOARD RECORDS

Section 1. Responsibility It shall be the duty of the recording secretary of the Board to maintain all Board files and records, including the official minutes of all meetings.

Section 2. Minutes

The recording secretary shall prepare an accurate record of all hearings and official actions of the Board, and the minutes representing such record shall be made available within a reasonable time after approval of the Board. Approved minutes shall be made available for inspection by the public in the Office of the County Surveyor.

Section 3. Tape Recordings

The recording secretary may make taped copies or other mechanical recordings of the Board's proceeding. Such recording products shall remain on file in the Surveyor's office for a period not less than one (1) year from the date of the hearing or determination, whichever is later. Such recordings shall not be removed from the Surveyor's office other than by order of a court of competent jurisdiction. Interested parties may listen to such recordings, under the supervision of the Surveyor's staff.

Section 4. Board Case Files

A file shall be maintained in the Surveyor's office for each item placed on the docket of the Board. Such files shall contain, as a minimum, the application form and supporting materials and any exhibits pertinent to the decision, conditions, or safeguards or other material related to the binding effects of the Boards actions.

Section 5. Public Records

The records and files for the Board shall be made available to the public under the provisions of IC 5-14-3, the Indiana Access to Public Records Law, and any amendments thereto. The County Surveyor is hereby designated as the officer responsible for determining which documents of the Board are public records. Any person may file a written objection to a decision of the Surveyor under this section. Upon receipt of such objection, the Surveyor shall consult the Board Chairman and the Board attorney who shall decide whether a requested document is public record.

ARTICLE X FEES

Section 1. Schedule of Fees

The Board may establish a uniform fee schedule of fees to defray the administrative costs

connected with processing and hearing petitions. Such fees shall not exceed the actual costs of providing such services. Fees established shall include fees for copying documents under the provisions of IC 5-14-3-8(d).

Section 2. Payment Required

In no case shall the Board take action on any petition for which applicable fees have not been paid in full. No part of any fee paid pursuant to this section shall be returnable to the petitioner.

Section 3. Waivers

Nothing herein shall be construed to require a fee for actions initiated in the public interest of the Board.

ARTICLE XI AMENDMENTS AND SUSPENSION

Section 1. Amendments

Amendments to the Rules and Procedure may be made by the Board at any regular or special meeting upon the affirmative vote of a majority of the membership of the Board, provided, however, that the proposed amendment shall have been presented in writing at a previous regular meeting of the Board. ARTICLE XII SEPARABILITY

If any section, clause, provision, or portion of these rules shall be held invalid or unconstitutional by a court of competent jurisdiction, such decision shall not affect the validity or constitutionality of any other section, clause, provision, or portion of these rules.

ARTICLE XIII CERTIFICATE OF ADOPTION These rules are hereby adopted by the affirmative vote of the Johnson County Drainage Board this 1st day of October, 1996; amended September 2, 1997; amended July 21, 1999; amended August 15, 2000; amended August 20, 2002, amended October 21, 2003.

RULES OF PROCEDURE ADOPTED: OCTOBER 1, 1996 AMENDED: September 2, 1997 AMENDED: July 21, 1999
AMENDED: August 15, 2000 AMENDED: August 20, 2002 AMENDED: October 21, 2003 AMENDED: December 20, 2006

5. Detail sand Specifications

Johnson County Surveyor's Office

Typical Tile Outlet

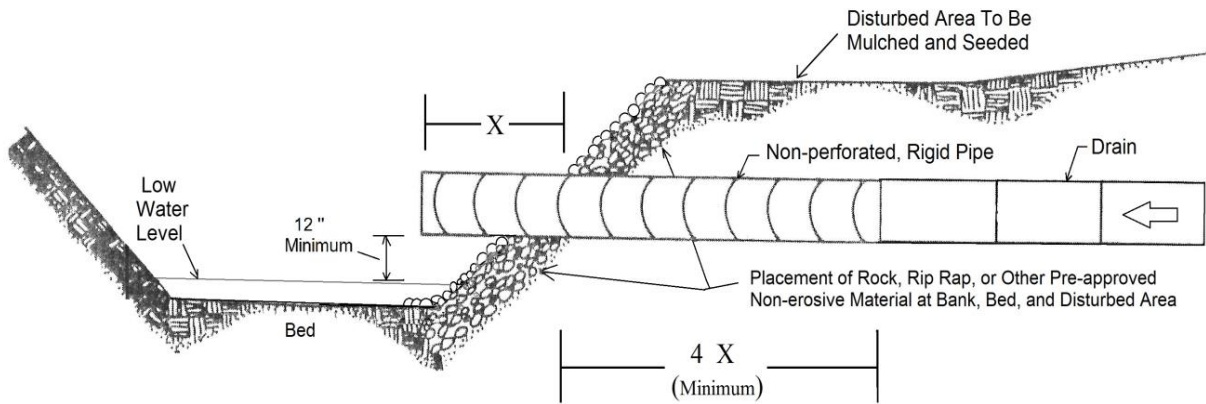

Note: Call for inspection prior to covering pipe, and at project completion.
Pipes 12 Inches and Above Require Headwall

Not To Scale
Revised May 10, 2021

Johnson Co Surveyors Office
86 W. Court Street, Franklin, Indiana
P. 317-346-4343

Johnson County Surveyor's Office

Typical Headwall Detail, Pipes 12 - 27 Inch

Not To Scale Rev. May 10, 2021

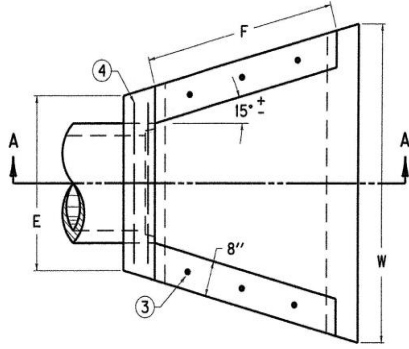

PLAN VIEW

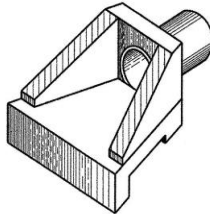

ISOMETRIC VIEW

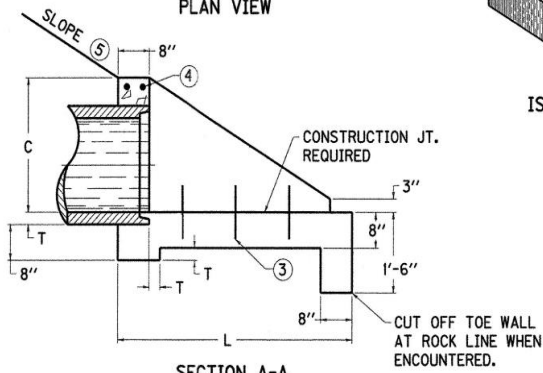

SECTION A-A

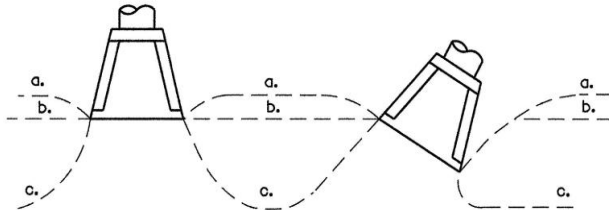

TOE OF SLOPES:
 a. STEEPER THAN 2:1
 b. 2:1
 c. FLATTER THAN 2:1

NOTES

- DIMENSIONS AND QUANTITIES ARE BASED ON CONCRETE PIPE AND WILL VARY INSIGNIFICANTLY FOR CORRUGATED METAL PIPE.
- REINFORCING STEEL : MINIMUM GRADE 40, BARS EVENLY SPACED.
- 6 - NO. 4 x 1'-0" DOWEL BARS.
- 2 - NO. 4 x (E DIMENSION MINUS 4").
- SLOPES SHALL BE WARPED TO FIT HEADWALL WHEN PIPE IS SKEWED AND/OR NORMAL SLOPE VARIES FROM 2:1.
- VOLUME DISPLACED BY PIPE COMPUTED USING INSIDE DIAMETER OF PIPE.
- WING ANGLES AND/OR DIMENSIONS MAY BE ALTERED DURING CONSTRUCTION TO ACCOMMODATE FLOW OF WATER.
- APRON BETWEEN WINGS SHALL BE SLOPED IN DIRECTION OF FLOW EQUAL TO SLOPE OF PIPE. FRONT FACE OF HEADWALL SHALL REMAIN VERTICAL.
- HEADWALLS ARE FOR CIRCULAR, ARCH, AND HORIZONTAL ELLIPTICAL 12"- 27" EQUIVALENT PIPE SIZES. SEE KENTUCKY HIGHWAY HEADWALL DWG. RDI- 016 FOR NON-CIRCULAR PIPE EQUIVALENT SIZES.

PIPE DIA. OR EQUIV. DIA.	SHAPE	DIMENSIONS						CLASS A CONC C. Y.	REINF STEEL LBS.
		C	E	F	L	W	T		
12"	○	1'-9"	2'-6"	2'-3"	3'-6"	4'-0"	2"	0.58	7
	○	2'-0"	2'-9"	2'-9"	4'-0"	4'-9"		0.75	
15"	○	1'-9"	3'-0"	2'-6"	3'-6"	4'-9"	2/4"	0.68	8
	○	2'-3"	3'-0"	3'-6"	4'-6"	5'-3"	2/2"	0.93	
18"	○	2'-0"	3'-6"	3'-0"	4'-0"	5'-6"		0.89	9
	○	2'-6"	3'-3"	4'-0"	5'-0"	6'-0"	2 3/4"	1.14	
21"	○	2'-3"	3'-0"	3'-6"	4'-6"	6'-0"		1.07	8
	○	2'-9"	3'-6"	4'-6"	5'-6"	6'-6"	3"	1.35	
24"	○	2'-6"	4'-0"	4'-0"	5'-0"	6'-9"		1.30	9
	○	3'-0"	3'-9"	5'-0"	6'-0"	7'-0"	3/4"	1.57	
27"	○	2'-9"	4'-6"	4'-3"	5'-3"	7'-3"		1.51	10
	○	3'-0"	4'-6"	4'-3"	5'-3"	7'-3"	3/2"	1.51	

This Exhibit is Based On The Kentucky Department of Highways, Sloped & Flared Headwalls for 12 Inch to 27 Inch Pipe, Standard Drawing No. RDH- 020- 03, Dated December 1st, 1999, as found at:

<https://transportation.ky.gov/Highway-Design/Pages/2016-Standard-Drawings.aspx>

Johnson Co Surveyors Office utilizes and recommends, but makes no claim, or guarantee written or implied as to the design, engineering, or correctness thereof. Petitioners engineer must review, design, correct, and certify all details pertaining to petitioners plans, reports, and exhibits.

Please Note: SLOPED & FLARED HEADWALLS FOR 12" TO 27" PIPE to be used in all Johnson County drainage outlets. Click link for additional details: <https://transportation.ky.gov/Highway-Design/Standard Drawings Sepias PDFs 2012/erdh020.pdf>